

Dual Antenna Mast DAM 6.0-P

Technical Data

Antenna height automatic adjustable from	1.0 to 6.0 m
Total mast height	6.5 m
Load capability	max. 20 kg (when balanced)
For long and heavy antennas a counter weight is required to balancing the load Depending on the distance of the antenna centre of gravity	
Material of antenna mast	Plastic + reinforced fibreglass weatherproof
Mast cross-section	100 mm x 100 mm (2 fibreglass tubes)
Base L x W	1.2 m x 0.7 m
Positioning speed adjustable between	2.0 to 16 cm/sec.
Positioning accuracy	± 1.0 cm
Pneumatic Polarisation	0°/90° (vert./hor.)
Positioning time	approx. 3 sec.
Polarisation drive	Pneumatic rotary actuator
Control	Solenoid valve
Pressure	max. 6 bar
Motors	Brushless stepper motors 200 W
Interference suppression:	20 dB under limits EN 55022 class B
Current consumption	max. 5A
Voltage	208-230 VAC, 50/60 Hz, single phase
Discharge current	25mA per drive unit (higher in the moment when powering on)
Control cable	Fibre optic lines
Remote control via	IEEE interface (optional Ethernet)
Antenna support drive	3 toothed belts
Material of toothed belts	Kevlar reinforced (non-metallic)
Bearings at mast slide	Ball bearings
Temperature range	+10 °C...+35 °C
Total weight	approx. 180 kg
Accessories	Interface to NCD Controller 1.5 m power supply cable Service manual

Information presented enclosed is subject to change as product enhancements are made regularly.
Pictures included are for illustration purposes only and do not represent all possible configurations.

Dual Antenna Mast DAM 6.0-P

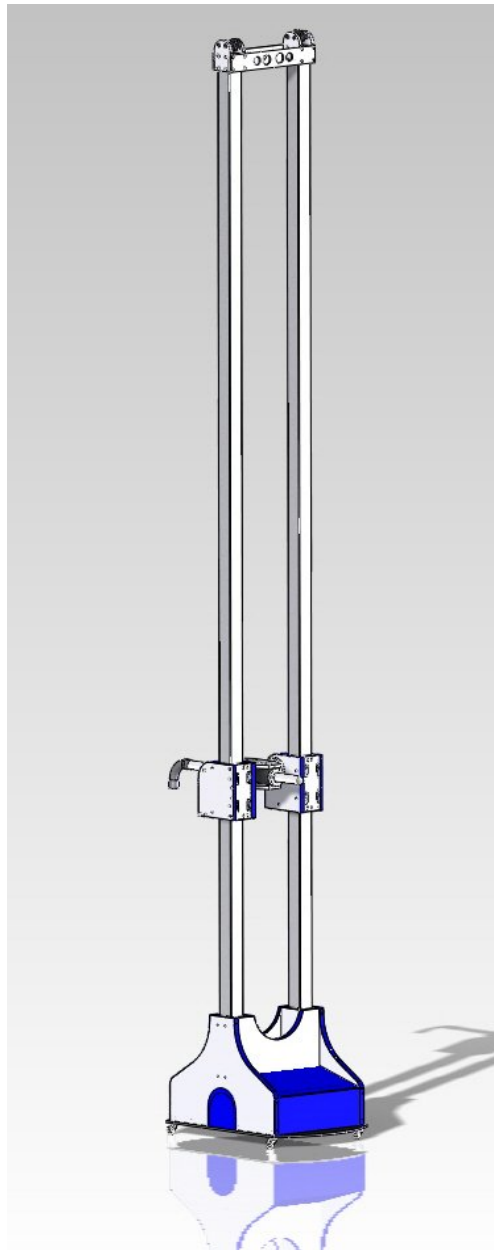

Brief description

The Dual Antenna Mast **DAM 6.0-P** is suitable in magnetic absorption chambers. The antenna mast, with the exception of the drive unit, is fabricated from plastic (PVC and reinforced fibreglass).

Metal parts are located only in the base plate and the drive mechanism (max. 0.3 m above ground level).

Antenna Adapters for all commercially available antennas are available upon request.
All antennas during polarisation rotate around their axis to eliminate any elevation errors.

The **IEEE 488.2 (GPIB) bus** provides an additional control option for all functions, when operated with the **NCD Controller**.