

Optical Clock Recovery Instrument TCR801 Datasheet



The TCR801 Optical Clock Recovery is a dual band clock recovery instrument centered around 26 and 53 Gb/s. The advanced architecture of the TCR801 allows the user to adjust Phase Lock Loop (PLL) bandwidth to comply with standards, and is a crucial component in the test and validation of the optical designs when used with other testing and measuring instruments.

Key features

- Designed to lock in two ranges:
 - 25.6 to 29 Gb/s PAM2/NRZ or PAM4
 - 51.2 to 58 Gb/s PAM2/NRZ or PAM4
- 1250 nm to 1650 nm wavelength
- Adjustable PLL bandwidths to configure the “Golden PLL” response required for the standard compliance testing
- IEEE Ethernet Control Interface, which runs the instrument remotely over the network using the stand-alone PC software or through PI using VISA/Tek-VISA.
- Provides two separate RF clock outputs
- Intelligent auto relock capability and manual relock functionality is available on the front panel of the instrument
- 2 x 20 LCD is used to view network IP address and current lock status, including the measured symbol rate

Applications

- Design/Verification of High-Speed Components and Systems
- Signal integrity analysis
- Compliance test for industry standards: 25G, 50G, 100G, 200G, 400G IEEE 802.3 standards such as 400GBASE-FR8, 400GBASE-DR4, and similar optical direct detect standards.

User interface

The TCR801 Optical Clock Recovery is operated with a simplified stand-alone user interface, with control from the Windows 10 or Windows Server UI. The communication between the Windows machine and the TCR801 Optical Clock Recovery is based on an IEEE 802.3 Ethernet network, such as 100BASE-T or 1000BASE-T standards. The corresponding Programmatic Interface (PI) commands are used in automation environments to control the instrument functionality.

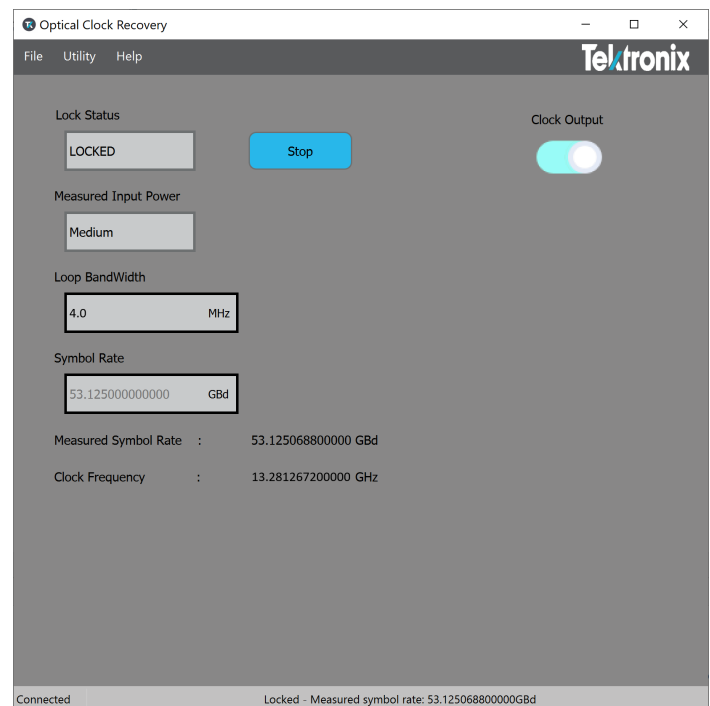

Figure 1: The user interface connected to a TCR801 Optical Clock Recovery and locked to a 53.125 Gb/s SSPRQ pattern

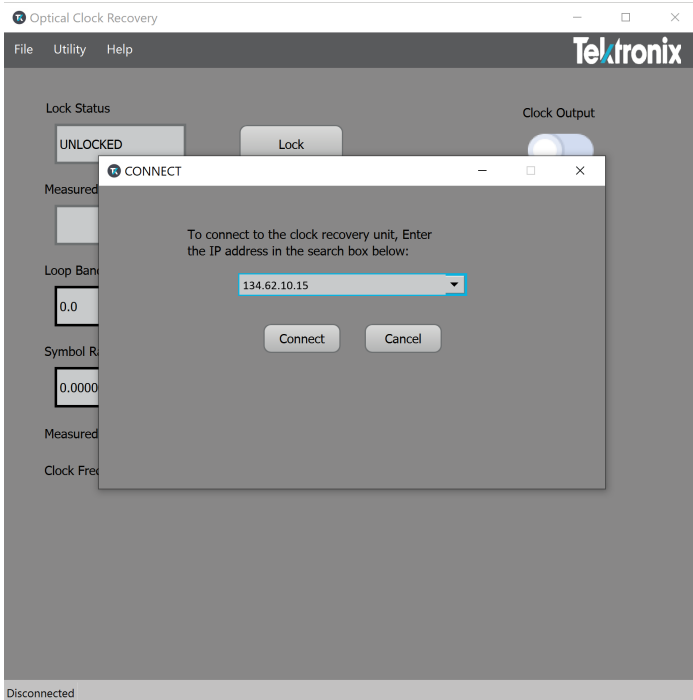
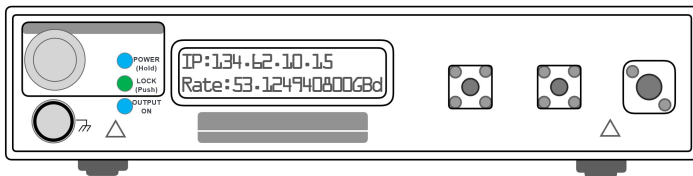

Figure 2: Connect the TCR801 Optical Clock Recovery unit by entering the IP address of the instrument



The TCR801 power button is multi-function. Press the power button to initiate a quick relock on the previously set symbol rate and hold to power off the instrument.

Compliance testing

The TCR801 Optical Clock Recovery compliance test for industry standards: 25G, 50G, 100G, 200G, 400G IEEE 802.3 standards such as 400GBASE-FR8, 400GBASE-DR4, and similar optical direct detect PAM4 standards. It also supports high speed NRZ standards such as 100 Gb Ethernet (100GBASE-LR4 or similar), which operates at the rate of 25.78125 Gb/s.

Compliant clock recovery

Golden PLL

Standards that use the Golden PLL for the compliance test rely on the TCR801 to recover the clock as per the IEEE 802.3 or similarly required loop bandwidth and roll-off.

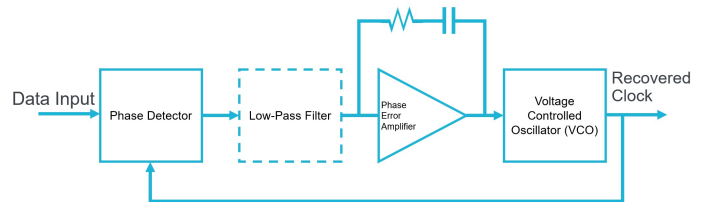

The communication standards specify the testing carried out using a recovered clock derived from the data signal. Typically, Phase Lock Loop requirements are defined in terms of -3 dB bandwidth of the recovery loop, the rate of roll-off of the frequency response, and the degree of response peaking allowable.

The TCR801 Optical Clock Recovery instrument has an advanced architecture supporting two ranges of input symbol rates, around >26 GBd and around >53 GBd, with loop bandwidths in the required range for both PAM2/NRZ and PAM4 signals.

The recovered clock is in the range of 13+ GHz.

Interoperable and flexible

The TCR801 Optical Clock Recovery is used with any sampling oscilloscope, BERT, or Pattern Checker/Error Detector. For example, the TCR801 can interface with Equivalent Time (Sampling) Oscilloscopes, such as the Tektronix DSA8300 or TSO820 instruments for optical testing at 26 GBd or 53 GBd.

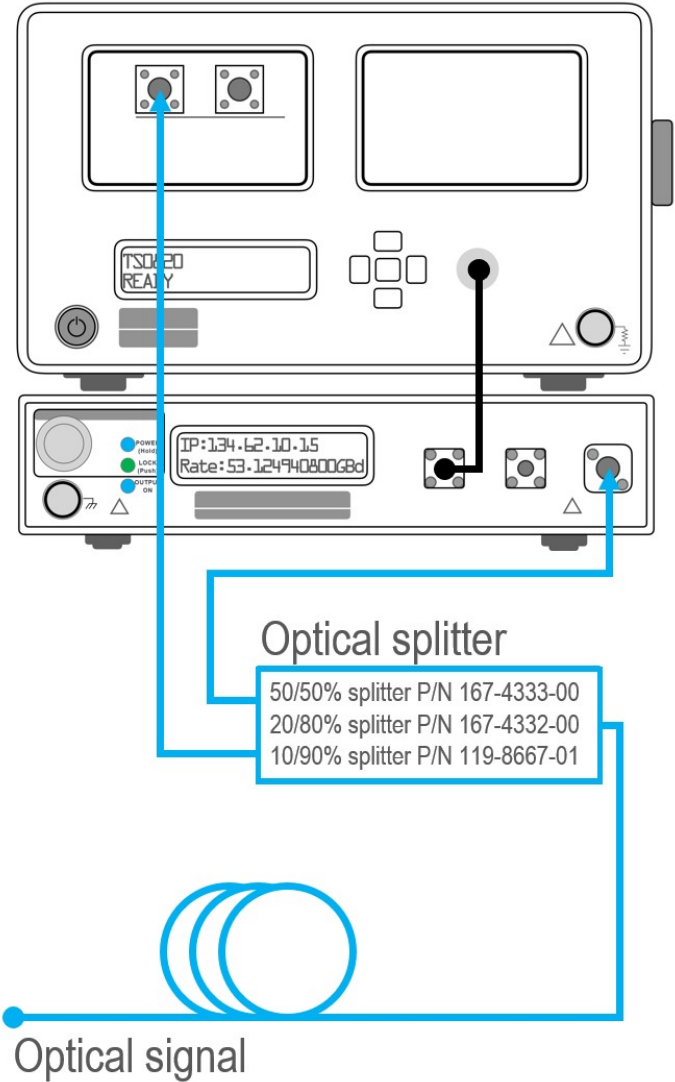

Figure 3: The TCR801 Optical Clock Recovery to TSO820 mainframe with an optical sampling module

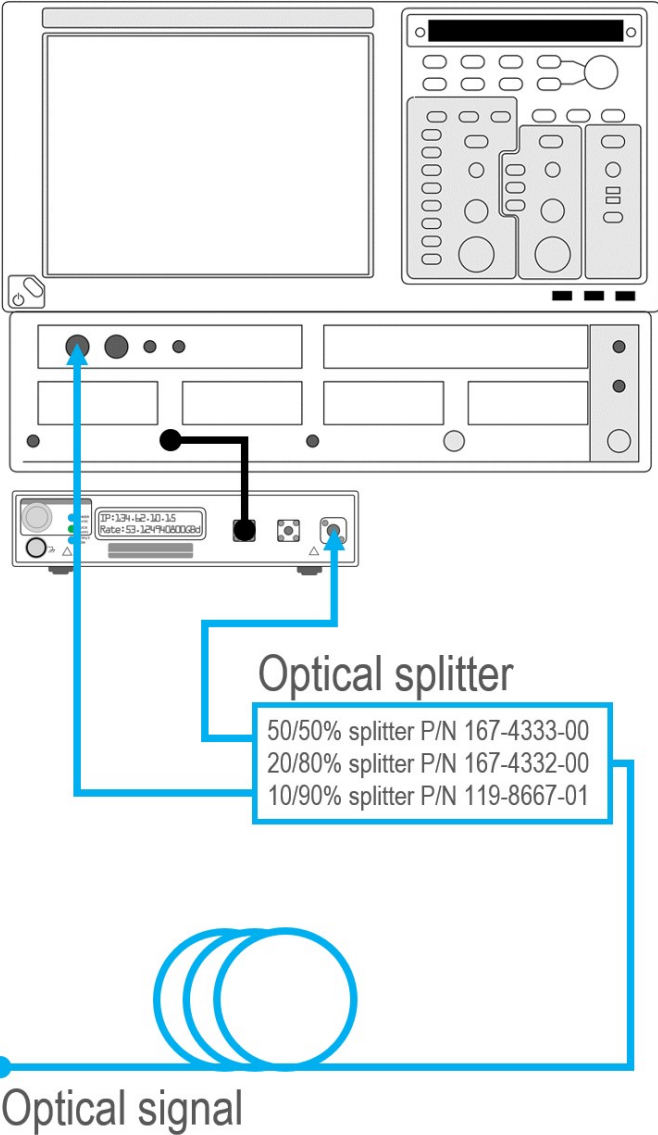

Figure 4: The TCR801 Optical Clock Recovery to DSA8300 mainframe with an optical sampling module

High-sensitivity operation accommodates low-amplitude signals

The TCR801 Optical Clock Recovery has high input sensitivity for applications involving low signals, which enables the user to use a wide variety of external optical splitters to trade off the power and is delivered to the TCR801 versus the acquisition platform (oscilloscope or error detector).

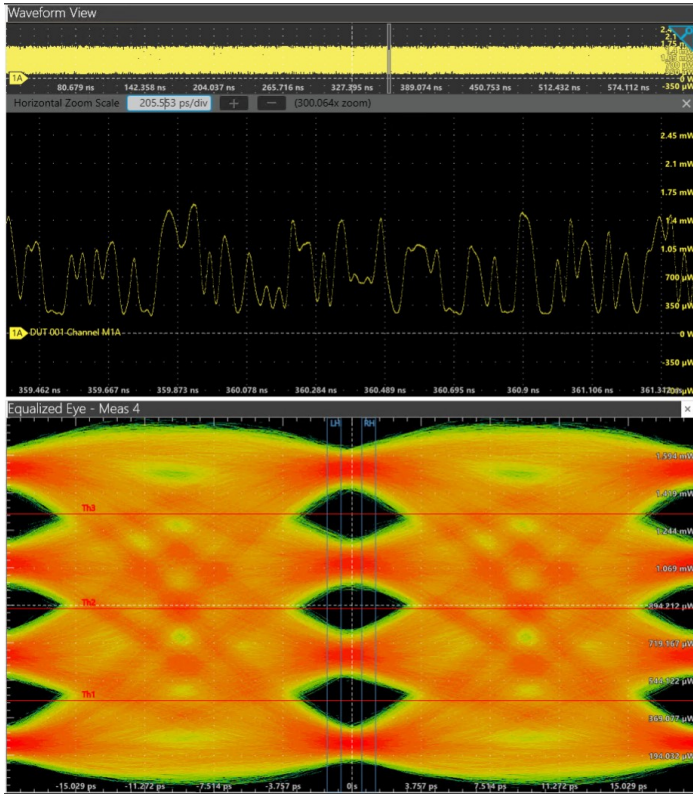

Figure 5: Example of a 53 Gb/s PRBS15 signal acquired on the Tektronix TSO820 Sampling Oscilloscope with TSO8C18 optical module, triggered by the TCR801 Optical Clock Recovery.

PC requirements

Windows 10 (64-bit) or Windows Server (64-bit)

Specifications

All specifications are guaranteed unless noted otherwise.

Instrument characteristics

Data interfaces	Single mode, FC/PC connector
Symbol rate coverage	Instrument operates over two nominal ranges (typical operation well beyond these) <ul style="list-style-type: none"> • 25.6 to 29 GBd • 51.2 to 58 GBd
Wavelength range	1250 nm to 1650 nm
Data insertion loss	External splitter recommended <ul style="list-style-type: none"> • 50/50% (included) • 20/80% • 10/90%
Data input power (max)	4 dBm at 1310 nm
Input sensitivity	-10 to 4 dBm at 1310 nm (typical, OMA) with PRBS13Q or similar - 8 to 4 dBm at 1310 nm (typical, OMA) with PRBS31Q, SSPRQ or similar Conditions <ul style="list-style-type: none"> • PAM4 modulated signal with TDECQ < 3.4 dB. Sensitivity at higher TDECQ might be lower depending on signal distortion. • OR PAM2/NRZ modulated signal passing 100GBASE-LR4 specification using pattern such as PRBS31 or other patterns with same or higher edge density.
Counter accuracy	+/- 10 ppm (typical)

Clock outputs

Clock interface	50 Ω single-ended, AC coupled. 3.5 mm SMA compatible connector
Clock output range	<p>For input data in range 25.6 to 29 GBd fBd / 2</p> <p>For input data in range 51.2 to 58 GBd fBd / 4</p>
Loop bandwidth	0.2 MHz to 10 MHz variable (typical)
Locking range	± 1000 ppm
Peaking	Response of the instrument is as required by IEEE 802.3bs with appropriate 20 dB/decade roll-off
Intrinsic jitter	<p>Typical 300 fs with 53.125 GBd PRBS13Q input, 4 MHz Loop Bandwidth</p> <p>Maximum 490 fs with 53.125 GBd SSPRQ input, 4 MHz Loop Bandwidth</p>
Output waveform Rise/Fall times (20/80%)	25 ps (typical), 30 ps (max)
Output amplitude	1 V _{pp} (typical)

Control

Control interface	IEEE 100BASE-T, 1000BASE-T, RJ45 connector
Device information	Serial number, revision codes are available for using software / PI

Physical

Height	56 mm (2.20 in.)
Depth	561 mm (22.09 in.)
Width	203 mm (7.99 in.)
Weight	4.5 kg (10 lbs.)

Environmental

Temperature

Operating	0 to 40°C
Nonoperating	-20 to 60°C

Relative humidity

Operating	95% at or below 30°C; 5-45% above 30°C to below 40°C
Nonoperating	95% at or below 30°C; 5-45% above 30°C to below 60°C

Acceleration (5-500 Hz)

Operating	0.27 g _{rms}
Nonoperating	2.28 g _{rms}

Ordering information

Clock recovery instruments

TCR801 26 and 53 GBaud Optical Clock Recovery Unit

Standard accessories

Power Supply External isolated Class 2 power supply. Tektronix P/N 119-8726-00
 Cable, Ethernet 2 m Ethernet cable (CAT6/RJ45). Tektronix P/N 174-7292-00
 50/50 splitter 50%/50% Single Mode FC/PC Splitter. Tektronix P/N 167-4333-00
 50 Ω termination Two 50 Ω termination. Tektronix P/N 015-1022-01

Service options

Opt. G3 Three Year Gold Care Plan. Includes expedited repair of all product failures including ESD and EOS, access to a loaner product during repair or advanced exchange to reduce downtime, priority access to Customer Support among others

Opt. G5 Five Year Gold Care Plan. Includes expedited repair of all product failures including ESD and EOS, access to a loaner product during repair or advanced exchange to reduce downtime, priority access to Customer Support among others

Opt. R3 Standard Warranty Extended to 3 Years. Covers parts, labor and 2-day shipping within country. Guarantees faster repair time than without coverage. All repairs include calibration and updates. Hassle free - a single call starts the process

Opt. R5 Standard Warranty Extended to 5 Years. Covers parts, labor and 2-day shipping within country. Guarantees faster repair time than without coverage. All repairs include calibration and updates. Hassle free - a single call starts the process

Opt. C3 Calibration service 3 years. Includes traceable calibration or functional verification where applicable, for recommended calibrations. Coverage includes the initial calibration plus 2 years calibration coverage

Opt. C5 Calibration service 5 years. Includes traceable calibration or functional verification where applicable, for recommended calibrations. Coverage includes the initial calibration plus 4 years calibration coverage.

Opt. D1 Calibration Data Report

Opt. D3 Calibration Data Report 3 Years (with Option C3)

Opt. D5 Calibration Data Report 5 Years (with Option C5)

Optional accessories

Accessories

TCR801 SPLT20 20%/80% Single Mode FC/PC Splitter. Tektronix P/N 167-4332-00
 TCR801 SPLT10 10%/90% Single Mode FC/PC Splitter. Tektronix P/N 119-8667-01

Certifications



Tektronix is registered to ISO 9001 and ISO 14001 by SRI Quality System Registrar.

ASEAN / Australasia (65) 6356 3900
Belgium 00800 2255 4835*
Central East Europe and the Baltics +41 52 675 3777
Finland +41 52 675 3777
Hong Kong 400 820 5835
Japan 81 (3) 6714 3086
Middle East, Asia, and North Africa +41 52 675 3777
People's Republic of China 400 820 5835
Republic of Korea +822 6917 5084, 822 6917 5080
Spain 00800 2255 4835*
Taiwan 886 (2) 2656 6688

Austria 00800 2255 4835*
Brazil +55 (11) 3759 7627
Central Europe & Greece +41 52 675 3777
France 00800 2255 4835*
India 000 800 650 1835
Luxembourg +41 52 675 3777
The Netherlands 00800 2255 4835*
Poland +41 52 675 3777
Russia & CIS +7 (495) 6647564
Sweden 00800 2255 4835*
United Kingdom & Ireland 00800 2255 4835*

Balkans, Israel, South Africa and other ISE Countries +41 52 675 3777
Canada 1 800 833 9200
Denmark +45 80 88 1401
Germany 00800 2255 4835*
Italy 00800 2255 4835*
Mexico, Central/South America & Caribbean 52 (55) 56 04 50 90
Norway 800 16098
Portugal 80 08 12370
South Africa +41 52 675 3777
Switzerland 00800 2255 4835*
USA 1 800 833 9200

* European toll-free number. If not accessible, call: +41 52 675 3777

For Further Information. Tektronix maintains a comprehensive, constantly expanding collection of application notes, technical briefs and other resources to help engineers working on the cutting edge of technology. Please visit www.tek.com.

Copyright © Tektronix, Inc. All rights reserved. Tektronix products are covered by U.S. and foreign patents, issued and pending. Information in this publication supersedes that in all previously published material. Specification and price change privileges reserved. TEKTRONIX and TEK are registered trademarks of Tektronix, Inc. All other trade names referenced are the service marks, trademarks, or registered trademarks of their respective companies.

19 Aug 2020 85W-61709-00
www.tek.com