

***Model 2171B / 2170B***  
**Antenna Positioning Tower**  
**User Manual**



*Model 2171B boresight*

ETS-Lindgren Inc. reserves the right to make changes to any products herein to improve functioning or design. Although the information in this document has been carefully reviewed and is believed to be reliable, ETS-Lindgren does not assume any liability arising out of the application or use of any product or circuit described herein; nor does it convey any license under its patent rights nor the rights of others. All trademarks are the property of their respective owners.

**© Copyright 2013–2018 by ETS-Lindgren Inc. All Rights Reserved. No part of this document may be copied by any means without written permission from ETS-Lindgren Inc.**

Trademarks used in this document: The *ETS-Lindgren* logo is a registered trademark, and *EMCenter* and *EMControl* are trademarks of ETS-Lindgren Inc.

**Revision Record**  
**MANUAL,2171B 2170B | Part #399364, Rev. E**

<b>Revision</b>	<b>Description</b>	<b>Date</b>
A	Initial Release	December, 2013
B	Updated <i>Boom Load Limitations</i> illustration	March, 2014
C	Updated <i>Recommended Tools, Assembly Instructions, Air Polarization Operation</i> ; added <i>Connecting Air Lines</i>	January, 2015
D	Updated bore sight link configurations; updated drawings in back of manual	June, 2015
E	Changed 2090 to EMCenter™	January, 2018

# Table of Contents

<b>Notes, Cautions, and Warnings .....</b>	<b>vii</b>
<b>1.0 Introduction .....</b>	<b>9</b>
ETS-Lindgren Patented Boresight System.....	9
Boresight Function (2171B Only).....	10
Non-Boresight Function .....	10
Positioning Controller (Required) .....	11
Standard Configuration.....	12
Tower Assembly.....	12
Variable Speed Motor .....	12
Links.....	12
Boresight with Centerline Pneumatic Polarization .....	12
Infrared (IR) Remote Controller .....	12
Fiber Optic Control Cables.....	12
Fiber Optic Shield Room Penetration Kit .....	12
Optional Items.....	12
Offset Boom .....	12
Additional Fiber Optic Cable .....	12
ETS-Lindgren Product Information Bulletin .....	13
<b>2.0 Maintenance .....</b>	<b>15</b>
Air Cylinder Maintenance .....	15
Maintenance Schedule .....	16
Every Three Months.....	16
Every Six Months .....	16
Every Twelve Months.....	16
Replacement and Optional Parts.....	16
Service Procedures .....	17
Contacting ETS-Lindgren.....	17
Sending a Component for Service .....	17
Calibration Services and Annual Calibration .....	17
<b>3.0 Specifications.....</b>	<b>19</b>
Electrical Specifications.....	19
Physical Specifications .....	19
<b>4.0 Electrical Installation .....</b>	<b>21</b>
Wire Gauge.....	21

Power Cord.....	21
Connecting the Positioning Controller.....	22
EMCenter RF Modular Platform.....	22
<b>5.0 Assembly Instructions .....</b>	<b>23</b>
Included and Recommended Tools.....	24
Included Tools.....	24
Recommended Tools.....	24
Parts to Assemble .....	24
Overview of Assembly Steps.....	25
Orientation of Parts during Assembly.....	26
Mast Orientation.....	26
Carrier Orientation.....	26
Base Orientation .....	27
Assembly Steps.....	28
Step 1—Remove Carrier from Temporary Shipping Mast.....	28
Step 2—Remove Temporary Shipping Mast from Base.....	29
Step 3—Slide Carrier onto (Main) Mast.....	30
Step 4—Begin Belt Installation .....	31
Step 5—Insert Mast into Base .....	34
Step 6—Connect Fiber Optic Cables.....	35
Step 7—Adjust the Timing .....	37
Step 8—Finish Installing the Belt.....	39
Step 9—Adjust Belt Tension.....	44
<b>6.0 Additional Installation and Adjustments.....</b>	<b>45</b>
Install Cable Antenna .....	45
Attach Optional Offset Boom .....	46
Install Boresight Links and Level Carrier (2171B Only) .....	48
Install Boresight Links .....	49
Level Carrier.....	50
Install Non-Boresight Links and Level Carrier (2171B Only).....	51
Install Non-Boresight Links .....	51
Level Carrier.....	51
<b>7.0 Operation.....</b>	<b>53</b>
Pre-Operational Checklist.....	53
Air Polarization Operation.....	54
Connecting Air Lines .....	55

Infrared Remote Controller .....	56
EMCenter Modular RF Platform .....	56
Edit Configuration Parameters .....	57
Tower Encoder Calibration .....	58
Start-Up .....	59
Shutdown .....	59
Mounting Antennas.....	59
Boom Load Limitations .....	60
<b>Appendix A: Warranty .....</b>	<b>61</b>
<b>Appendix B: EC Declaration of Conformity .....</b>	<b>63</b>
<b>Appendix C: Drawings.....</b>	<b>65</b>

This page intentionally left blank.

## Notes, Cautions, and Warnings

---



**Note:** Denotes helpful information intended to provide tips for better use of the product.



**CAUTION:** Denotes a hazard. Failure to follow instructions could result in minor personal injury and/or property damage. Included text gives proper procedures.



**WARNING:** Denotes a hazard. Failure to follow instructions could result in **SEVERE** personal injury and/or property damage. Included text gives proper procedures.



**Note:** See the ETS-Lindgren *Product Information Bulletin* for safety, regulatory, and other product marking information.

This page intentionally left blank.



## 1.0 Introduction

---

The **ETS-Lindgren Model 2171B/2170B Antenna Positioning Tower** meets ANSI C63.4 requirements for measurements above 1 GHz by keeping the antenna aimed at the equipment under test (EUT) while the antenna ascends and descends the mast. This is especially useful when high gain directional antennas are used.

The Model 2171B easily adjusts for non-boresight testing and for 3-m, 5-m, and 10-m boresight testing.

The Model 2171B/2170B is constructed as a single-piece mast of high density fiberglass-reinforced polymer square tubing. This material has a high degree of immunity from extended exposure to sunlight. The Model 2171B/2170B is also designed with a reduced base for easier maneuverability in smaller chambers.

A toothed belt drive provides smooth ascent and descent of the carrier assembly. The belt is an industrial grade composite that was selected for strength and longevity.



*Model 2171B boresight  
(antenna not included)*

The Model 2171B/2170B features variable speed operation with speed rates that range from 3 cm/sec to 22 cm/sec, as controlled by an ETS-Lindgren positioning controller. For more information on the positioning controller, see page 11.

The Model 2171B/2170B accepts stinger and other standard ETS-Lindgren antenna mounts. See *Mounting Antennas* on page 59 for more information.

### **ETS-Lindgren Patented Boresight System**

---

The Model 2171B provides the ETS-Lindgren patented boresight system to provide direct antenna aim on EUT during scanning. This boresight meets the requirements of ANSI C63.4 2003 and 2009 for compliance with FCC measurements above 1 GHz.

During scans, the boresight system maintains constant directional antenna positioning while varying the angle between the antenna and the mast. This is particularly important when using higher gain antennas of more than 3 dBi. As the antenna is raised above the ground, the tilt of the antenna will maintain the EUT within the half power (-3 dB) beamwidth.



**Note:** The following drawings use a generic positioning tower to illustrate boresight and non-boresight function.

### BORESIGHT FUNCTION (2171B ONLY)

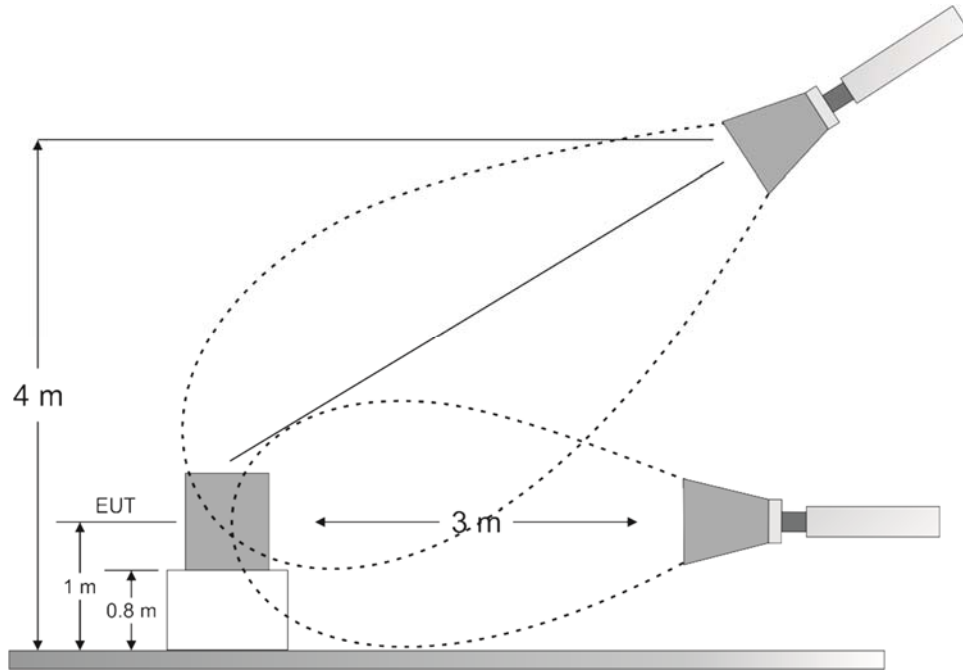

### NON-BORESIGHT FUNCTION

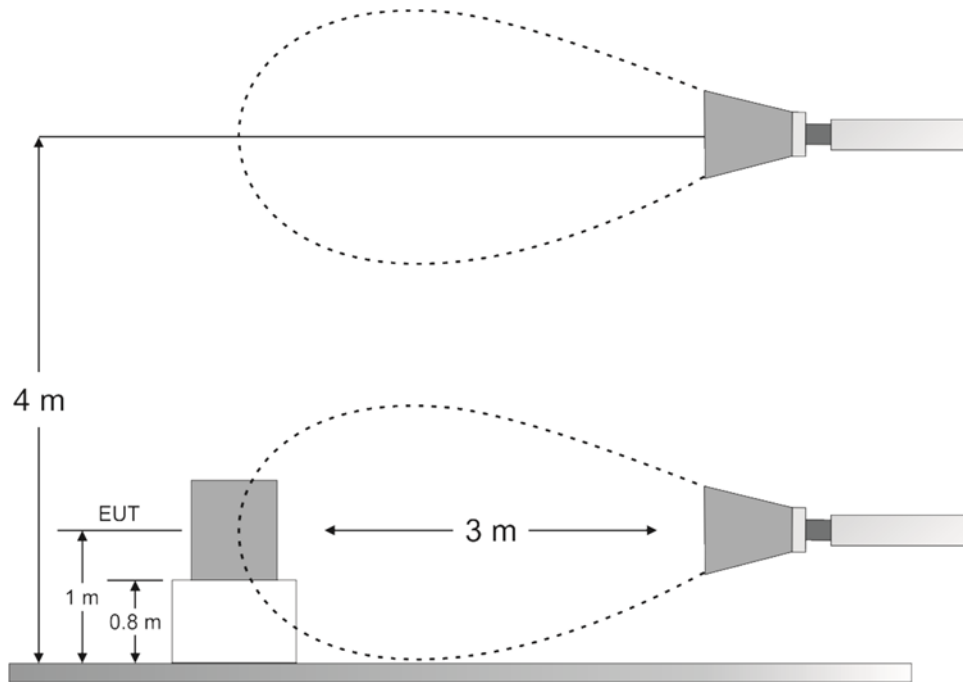

## Positioning Controller (Required)

---

A positioning controller such as the ETS-Lindgren EMCenter™ Modular RF Platform (with EMControl™ Positioner Controller Plug-In Card) is required for operation, and is sold separately. Contact ETS-Lindgren for ordering information. The EMCenter replaces the 2090 Controller, which has been discontinued. The basic controller configuration is an EMCenter with an EMControl card. This assembly is ETS part number 125241.

Check [ets-lindgren.com](http://ets-lindgren.com) or contact ETS-Lindgren to ensure that your EMCenter, the EMControl card, the backplane, and display all have the current firmware versions.

**EMCenter:** V5.21 (or later)

**EMControl (7006-001) Card:** V2.5.6 (or later)

**Backplane:** V2.3.0 (or later)

**Display:** V1.4.10 (or later)

The EMCenter is also expandable with a variety of additional options available. Please contact ETS-Lindgren with any questions.



**Note:** Existing ETS-Lindgren positioning controllers can be used with the Model 2171B/2170B; contact ETS-Lindgren to confirm your controller is installed with the required firmware.

The 2090 requires firmware revision V 3.21 or higher. It is available for download at [ets-lindgren.com](http://ets-lindgren.com) and requires the program Flash Upgrade Wizard V 4.0 (also available at [ets-lindgren.com](http://ets-lindgren.com)).

## Standard Configuration

---

**TOWER ASSEMBLY**     Single-piece mast, casted base, carrier assembly

### **VARIABLE SPEED MOTOR**

**LINKS**     Non-boresight and 3-, 5-, and 10-meter for boresight

**BORESIGHT WITH CENTERLINE PNEUMATIC POLARIZATION**     With adjustable rotational velocity

**INFRARED (IR) REMOTE CONTROLLER**     See page 53

**FIBER OPTIC CONTROL CABLES**     3- and 10-meter

**FIBER OPTIC SHIELD ROOM PENETRATION KIT**     Routes the fiber optic control cable from the control room to the shield room while maintaining shielding attenuation. The pieces are made of brass for conductivity and provide attenuation of greater than 100 dB at 10 GHz. A single 25-mm (1.0-in) hole is required for mounting.

## Optional Items

---

### **OFFSET BOOM**

An optional offset boom is available (part# 118617). Contact ETS-Lindgren Sales Department for more information.

### **ADDITIONAL FIBER OPTIC CABLE**

Various lengths of fiber optic cable are available by custom order. The standard length provided is 10 m (32.8 ft).

## **ETS-Lindgren Product Information Bulletin**

---

See the ETS-Lindgren *Product Information Bulletin* included with your shipment for the following:

- Warranty information
- Safety, regulatory, and other product marking information
- Steps to receive your shipment
- Steps to return a component for service
- ETS Lindgren calibration service
- ETS Lindgren contact information

This page intentionally left blank.

## 2.0 Maintenance

---



**CAUTION:** Before performing any maintenance, follow the safety information in the ETS-Lindgren *Product Information Bulletin* included with your shipment.



**WARNING:** Maintenance of Model 2171B/2170B is limited to the instructions provided here. If you have any questions concerning maintenance, contact ETS-Lindgren Customer Service.



Do not make any modifications to this unit without consulting the factory directly.



Only use replacement parts and fasteners ordered directly from the factory.



This equipment should be operated and maintained by qualified personnel.

Disconnect all air supply lines when servicing pneumatic components.

Service equipment in accordance with the maintenance schedule provided.

Periodically check belt for wear.

### Air Cylinder Maintenance

---

The air cylinder uses a special O-ring lubricant: silicon grease designed specifically for O-rings. During maintenance apply this type of silicon grease to prevent excessive wear of the O-rings.

## Maintenance Schedule

---

### EVERY THREE MONTHS

- Inspect belt for wear, tension, and cracking.
- Check all screws and bolts to confirm that are tight per assembly instructions.
- Inspect bolts and hardware for breakage.

### EVERY SIX MONTHS

- Check connecting control and all cables for degradation from environment and use. If necessary, replace per safety per local electrical codes.

### EVERY TWELVE MONTHS

- Use high-grade silicone grease on all carrier rollers.

## Replacement and Optional Parts

---



**Note:** ETS-Lindgren may substitute a similar part or new part number with the same functionality for another part/part number. Contact ETS-Lindgren for questions about part numbers and ordering parts.

Following are the part numbers for ordering replacement or optional parts for the Model 2171B/2170B.

Part Description	Part Number
<b><u>Boresight links</u></b>	
3-meter link	119612
5-meter links	119613 (LH), 119665 (RH)
10-meter links	119614 (LH), 119666 (RH)
<b><u>Non-boresight link</u></b>	
1 1/2-in link	118050
1-in link	118051
Cam knob	118052
Cam lock knob	118059
Offset boom, 2171B/2170B	118617
Timing Belt (33 ft required)	880393
Fuse, 5 x 20mm 3A Slow	480029



### CONTACTING ETS-LINDGREN



**Note:** Please see [ets-lindgren.com](https://www.ets-lindgren.com) for a list of ETS-Lindgren offices, including phone and email contact information.

### SENDING A COMPONENT FOR SERVICE

For the steps to return a system or system component to ETS-Lindgren for service, see the *Product Information Bulletin* included with your shipment.

### CALIBRATION SERVICES AND ANNUAL CALIBRATION

See the *Product Information Bulletin* included with your shipment for information on ETS-Lindgren calibration services.

This page intentionally left blank.

### 3.0 Specifications

---

#### Electrical Specifications

---

<b>Voltage:</b>	220 VAC
<b>Amp:</b>	5.0
<b>Line Frequency:</b>	50/60 Hz
<b>Phase:</b>	Single

#### Physical Specifications

---

<b>Polarization:</b>	30° per second
<b>Scan Range:</b>	1.0 m—4.0 m (39.37 in—157.48 in)
<b>Speed Range:</b>	3 cm/sec to 22 cm/sec
<b>Cross-Boom Loading:</b>	10.4 kg (23.0 lb)
<b>Separation Distance (boresight):</b>	3 m, 5 m, 10 m
<b>Weight (approximate):</b>	80 kg (175.0 lb)
<b>Maximum Overall Height:</b>	<b>2171B:</b> 4.9 m (193 in) <b>2170B:</b> 4.2 m (165 in)
<b>Base Dimensions (LxW):</b>	1.2 m (47.5 in) x 0.8 m (34.0 in)

This page intentionally left blank.

## 4.0 Electrical Installation

---



**CAUTION:** Before connecting any components, follow the safety information in the ETS-Lindgren *Product Information Bulletin* included with your shipment.



Electrical installation must be performed by a qualified electrician, and in accordance with local and national electrical standards.



Make sure the power is off and secured before proceeding.

### Wire Gauge

---

Whenever possible the motor should be powered from a separate branch circuit of adequate capacity to keep voltage drop to a minimum during startup and running. For longer runs, increase the wire size in accordance with the following wire selection guide.



**Note:** Never use smaller than 14 AWG for any installation.

<b>Length of Wire @ 220 V:</b>	0-15.24 m (0-50 ft)	15.24-30.48 m (50-100 ft)	30.48-60.96 m (100-200 ft)
<b>Wire Gauge Required:</b>	14 AWG	14 AWG	14 AWG

### Power Cord

---

The motor base is provided with an input AC power cord that is approximately 2.45 m (8 ft) long. This power cord is suitable for portable or indoor applications without modification.

### EMCENTER RF MODULAR PLATFORM

The ETS-Lindgren EMCenter™ Modular RF Platform (with EMControl™ Positioner Controller Plug-In Card) may be used to control the Model 2171B/2170B Antenna Positioning Tower. For information on connecting and using the EMCenter, see the *EMCenter Modular RF Platform User Manual*, available for download at [ets-lindgren.com](http://ets-lindgren.com).

The EMCenter replaces the 2090 Controller, which has been discontinued. The basic controller configuration is an EMCenter with an EMControl card. This assembly is ETS part number 125241.

Check [ets-lindgren.com](http://ets-lindgren.com) or contact ETS-Lindgren to ensure that your EMCenter, the EMControl card, the backplane, and display all have the current firmware versions.

**EMCenter:** V5.21 (or later)

**EMControl (7006-001) Card:** V2.5.6 (or later)

**Backplane:** V2.3.0 (or later)

**Display:** V1.4.10 (or later)

The EMCenter is also expandable with a variety of additional options available. Please contact ETS-Lindgren with any questions.



**Note:** If you are unfamiliar with the operation of the EMCenter, see the manual, available for download from [ets-lindgren.com](http://ets-lindgren.com).

The EMCenter replaces the 2090 Controller, which has been discontinued.

The 2090 requires firmware revision V 3.21 or higher. It is available for download at [ets-lindgren.com](http://ets-lindgren.com) and requires the program Flash Upgrade Wizard V 4.0 (also available at [ets-lindgren.com](http://ets-lindgren.com)).



**CAUTION:** Fiber optic cabling for each device should not hang unsupported from the rear panel of the EMCenter. The fibers and connectors are easily broken if twisted or bent. Keep the fiber optic cables as straight as possible from the connector to the protective sheath.

## 5.0 Assembly Instructions

---



**CAUTION:** Before connecting any components, follow the safety information in the ETS-Lindgren *Product Information Bulletin* included with your shipment.



This equipment should be installed, operated, and maintained by qualified personnel.



**Stay clear of all moving components on this equipment.**

**Never stand beneath the carrier, whether moving or stationary.**



**Note:** You will require assistance from two or more team members to assemble the Model 2171B/2170B.



**Note:** See the ETS-Lindgren *Product Information Bulletin* included with your shipment for information on unpacking and acceptance procedures.

The Model 2171B/2170B Antenna Positioning Tower should be assembled in the location where it will be used. If movement to another location is required after assembly, partial disassembly will be required for it to fit through most doorways.

## Included and Recommended Tools

---

### INCLUDED TOOLS

- **Part# 891780:** Adjustable Wrench, 1-1/8" Jaw (quantity: 2). For all hex nuts.
- **Part# 891781:** Hex L-Key, 3/16" Hex (quantity: 1). For cam rollers on motor base.
- **Part# 120927:** Fiber Optic Connector Tool (quantity: 1). For fiber optic connection on mast.

### RECOMMENDED TOOLS

- Work bench or two sawhorses
- Medium-sized level

## Parts to Assemble

---

These main parts are used to assemble the Model 2171B/2170B:

- Mast
- Carrier
- Belt
- Base



**Note:** The Model 2171B/2170B ships with a small temporary shipping mast. The carrier is installed on this small mast and then inserted into the base for stability during transit. The temporary shipping mast should never be used for operation.



Boresight shown;  
antenna not included



## Overview of Assembly Steps

---

1. Remove carrier from temporary shipping mast—see page 28.
2. Remove temporary shipping mast from base—see page 29.
3. Slide carrier onto (main) mast—see page 30.
4. Begin belt installation—see page 31.
5. Insert mast into base—see page 34.
6. Connect fiber optic cables—see page 35.
7. Adjust the timing—see page 37.
8. Finish installing the belt—see page 39.
9. Adjust belt tension—see page 44.

## Orientation of Parts during Assembly

---

### MAST ORIENTATION

The fiber optic connectors are located on the front of the mast.

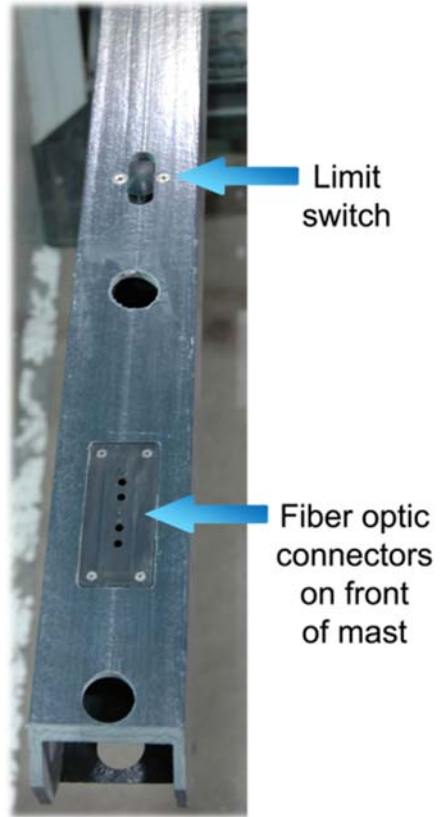

### CARRIER ORIENTATION

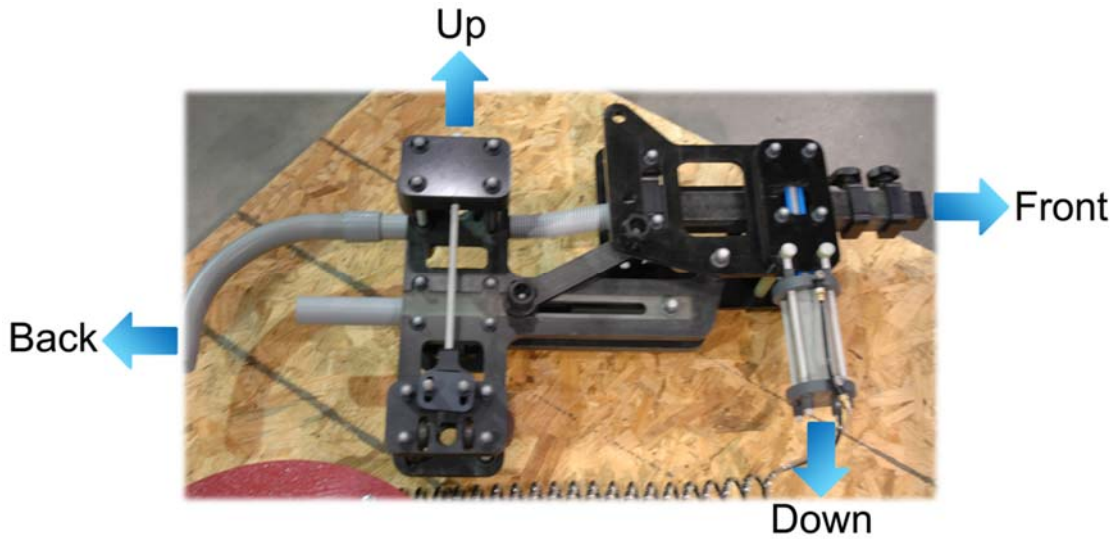

## BASE ORIENTATION

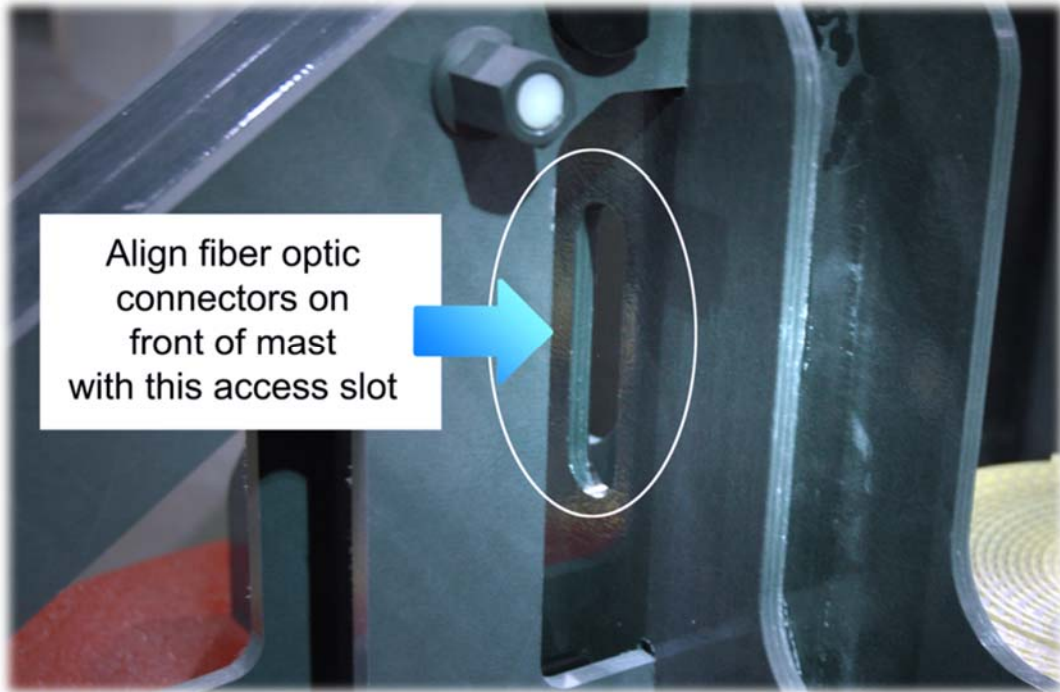

## Assembly Steps

---



**CAUTION: TAKE CARE TO AVOID DAMAGE TO FIBER OPTIC CABLES:** Never pull, pinch, bend, twist, or place any kind of stress on the fiber optic cables.

### **STEP 1—REMOVE CARRIER FROM TEMPORARY SHIPPING MAST**

With the base on the floor and the temporary shipping mast in a vertical position, carefully lift the carrier straight up, sliding it off of and away from the temporary shipping mast.

## STEP 2—REMOVE TEMPORARY SHIPPING MAST FROM BASE



**Note:** Never use the temporary shipping mast for operation.

In the following view the carrier and belt are shown, but only the mast is present during this step.

Remove the two base studs by rotating and then pulling straight out.

Lift up to remove the temporary shipping mast from the base.

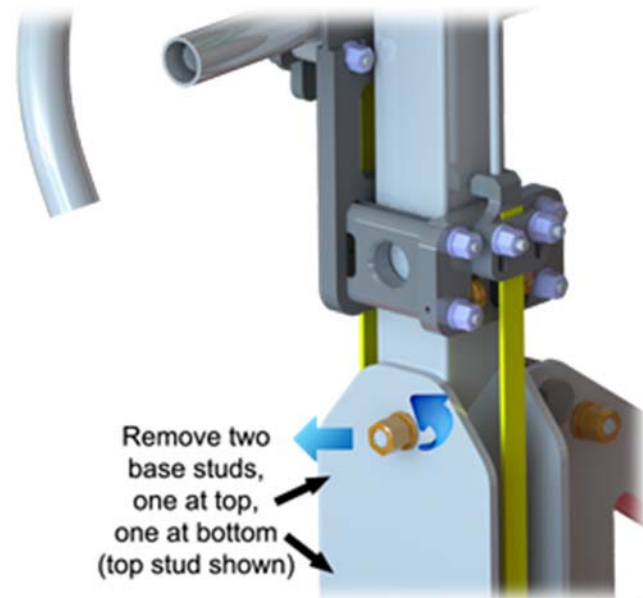



**Note:** Make sure to orient the carrier and mast as shown in *Orientation During Assembly* on page 26.

### STEP 3—SLIDE CARRIER ONTO (MAIN) MAST

Place the mast horizontally onto an elevated, stable surface, such as across two sawhorses.

Carefully slide the carrier onto the mast from the bottom of the mast. Orient the carrier so that when the mast is inserted into the base:

- The air cylinder is on the same side of the mast as the fiber optic connectors; and
- When the mast is upright, the air cylinder will point downward.



#### **STEP 4—BEGIN BELT INSTALLATION**

Remove the belt clamp plate by removing the four hex nuts.

With the teeth facing inward, place one end of the belt in the notch, and then replace the belt clamp plate and hex nuts.

Route the belt up the carrier, over the top of the mast, and then back down to the carrier.

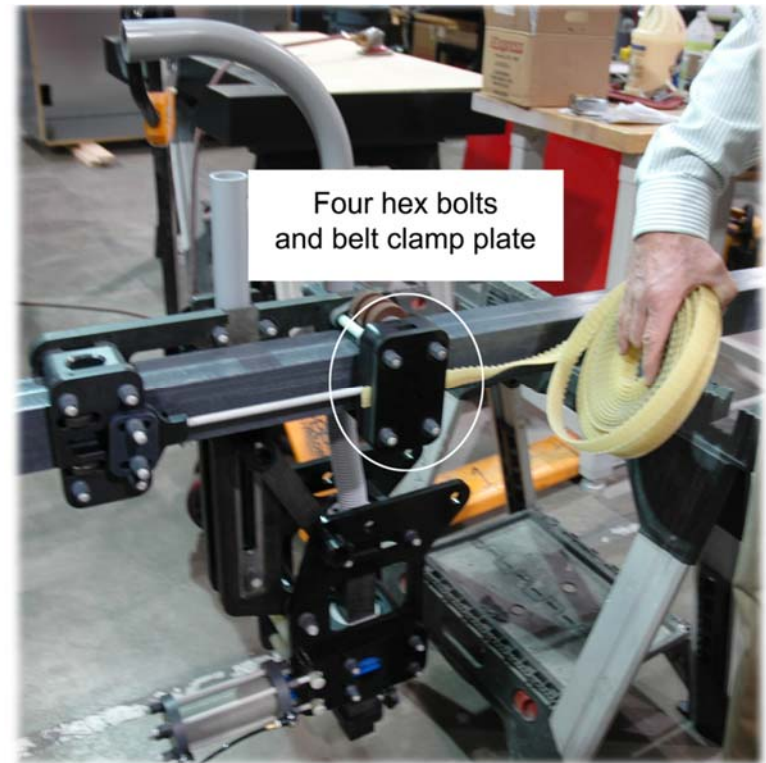



Route the belt to the top of the mast, over the pulleys, and down the other side of the mast.



Remove the four hex nuts to remove the timing pulley plate.





Thread the belt over the timing pulley.

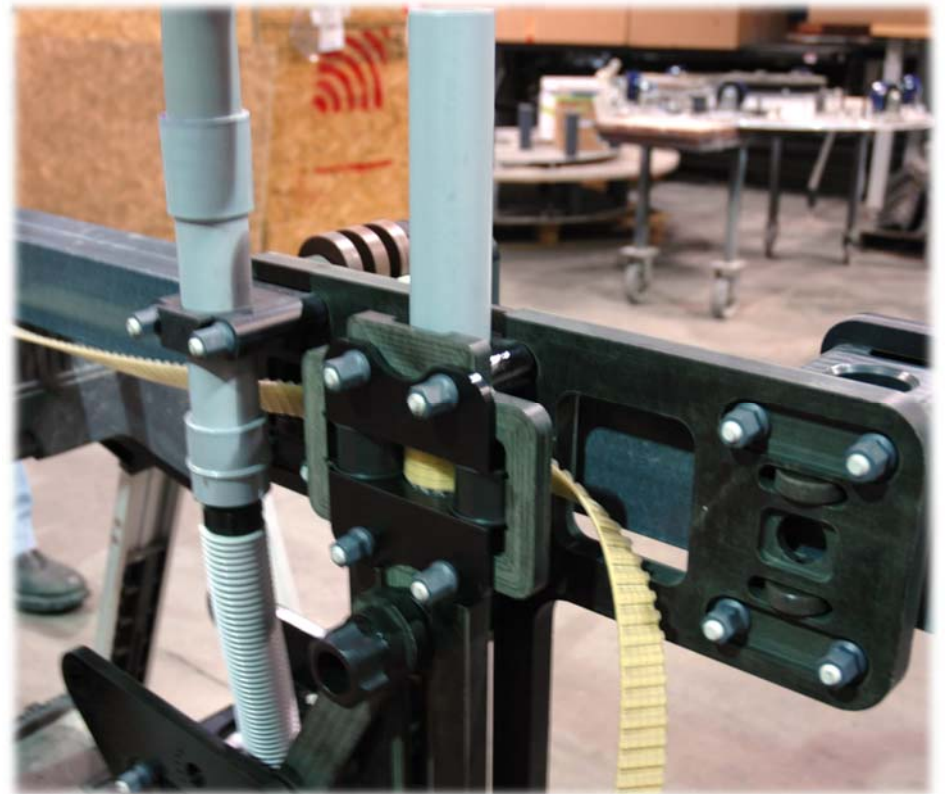

Replace the plate and four hex nuts to keep the belt in place while you move the mast into a vertical position; you will remove the plate and hex nuts again to adjust the timing in step 7 on page 37.



**Note:** Make sure to orient the carrier and mast as shown in *Orientation During Assembly* on page 26.

### STEP 5—INSERT MAST INTO BASE

Carefully move the mast and carrier into a vertical position and slide the mast into the base, aligning the fiber optic connectors on the front of the mast with access slot on the front of the base.

Replace the two base studs removed in step 2 on page 29.

Adjust the carrier height by moving the carrier past the lower limit switch until it stops at rest on the top of the base.





**CAUTION: TAKE CARE TO AVOID DAMAGE TO FIBER OPTIC CABLES:** Never pull, pinch, bend, twist, or place any kind of stress on the fiber optic cables.

## STEP 6—CONNECT FIBER OPTIC CABLES

Carefully plug the fiber optic cables through the access slot on the front of the base and into the fiber optic connectors located on the front of the mast.

Two of the cables are marked **U** for the UPPER limit and two are marked **L** for the LOWER limit; plug the two cables marked **U** into the connectors marked **U** on the mast, and plug the two cables marked **L** into the connectors marked **L**.

Either **U** cable can be plugged into either of the **U** connectors; either **L** cable can be plugged into either of the **L** connectors.

When completely plugged in, the outer flange on the cable should be flush with the surface of the mast.

Always use the flange on the cable to connect or disconnect the fiber optic cables; never pull or push the fiber optic cable using the collar or the cable.

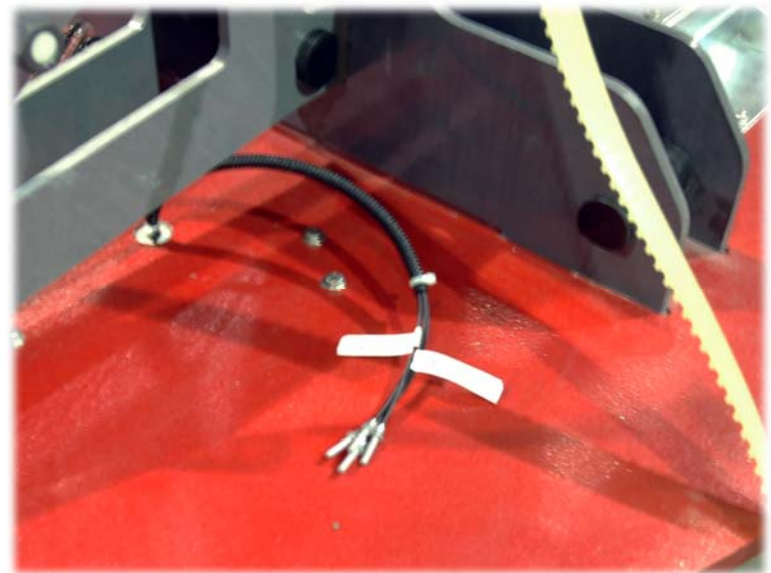

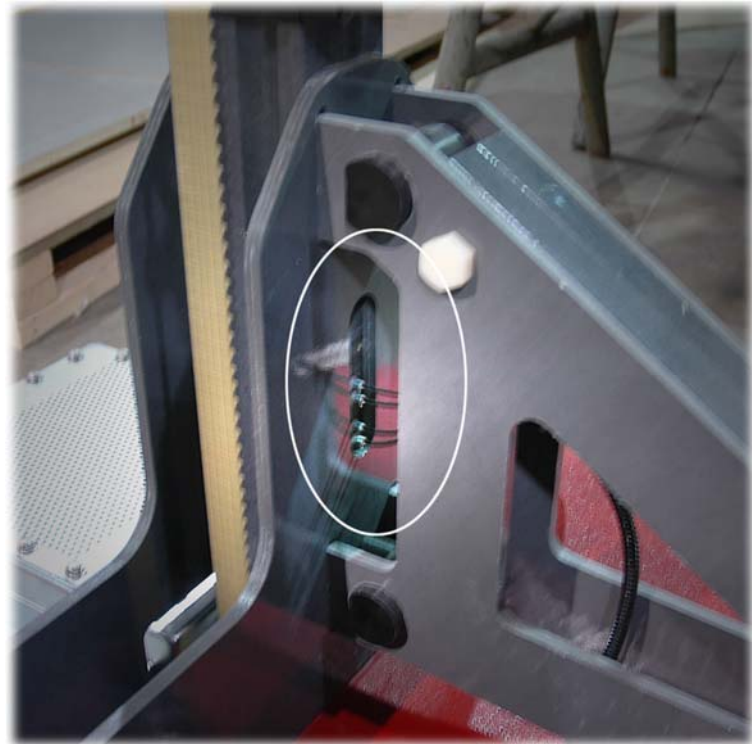
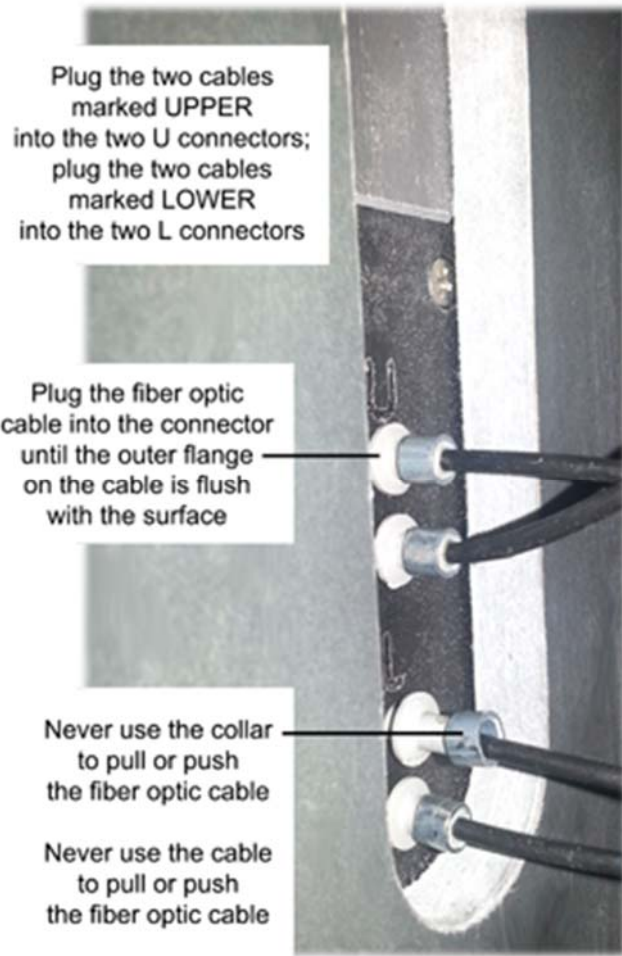

### STEP 7—ADJUST THE TIMING

Remove the four hex nuts and the timing pulley plate.

To adjust the timing between the boresight and the carrier:

- Manually rotate the timing pulley to move the cam link back toward the mast to the limit of its travel.

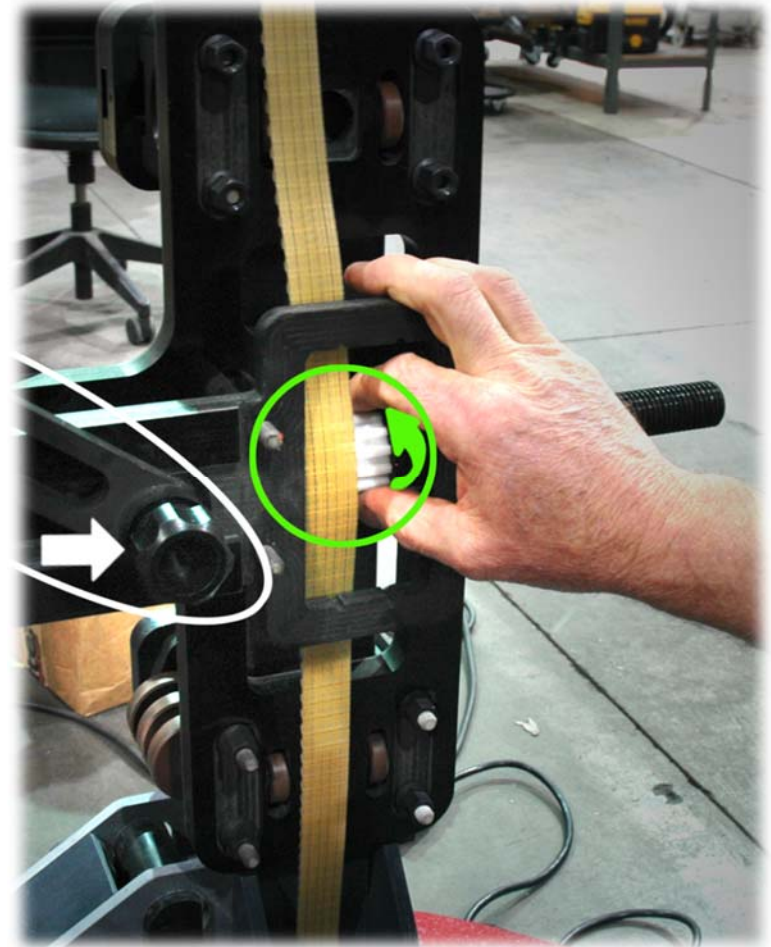

- Roll the pulley to engage the teeth and then pull the belt up, taking care to keep slack out of the lower section of belt between the motor base and the timing pulley.
- When done, replace the plate and four hex nuts.



### STEP 8—FINISH INSTALLING THE BELT

Four cam followers are located on the underside of the base next to motor base pulley.



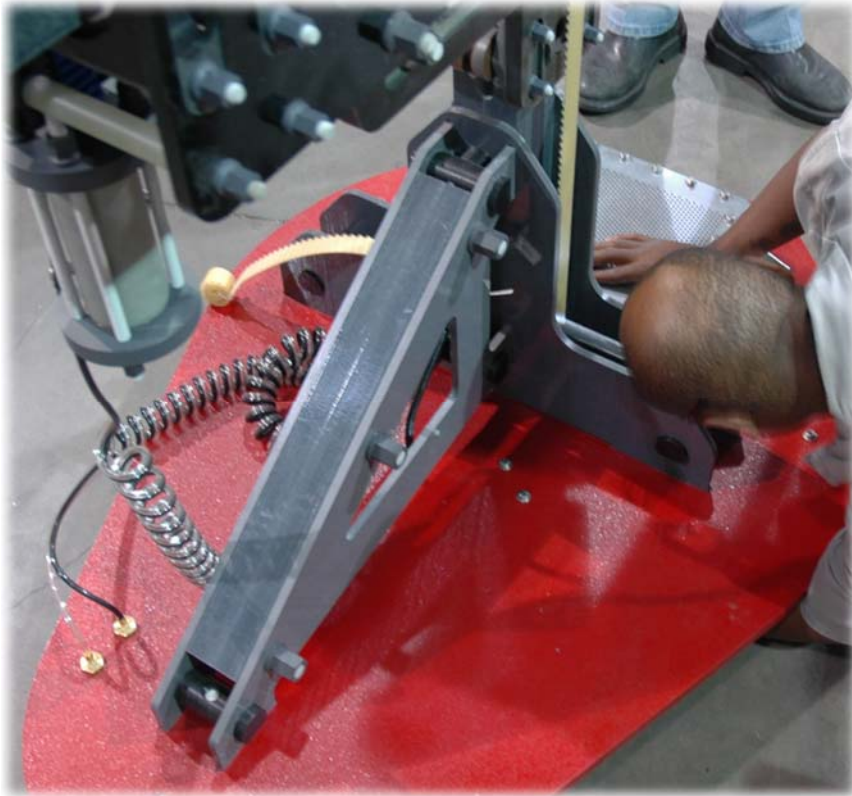

Reach under the base to access and remove the four cam followers with an Allen wrench.



View of two cam followers removed.



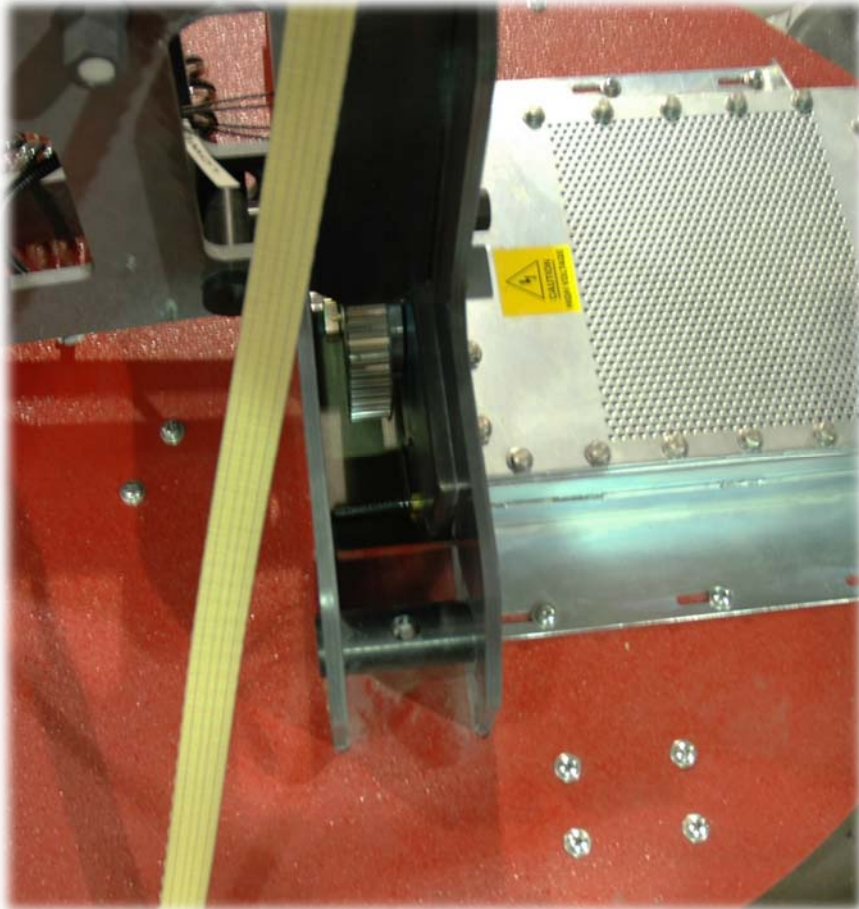

View of motor base pulley with cam followers removed.  
With teeth facing inward, continue routing the belt down,  
around the motor base pulley, and back up.

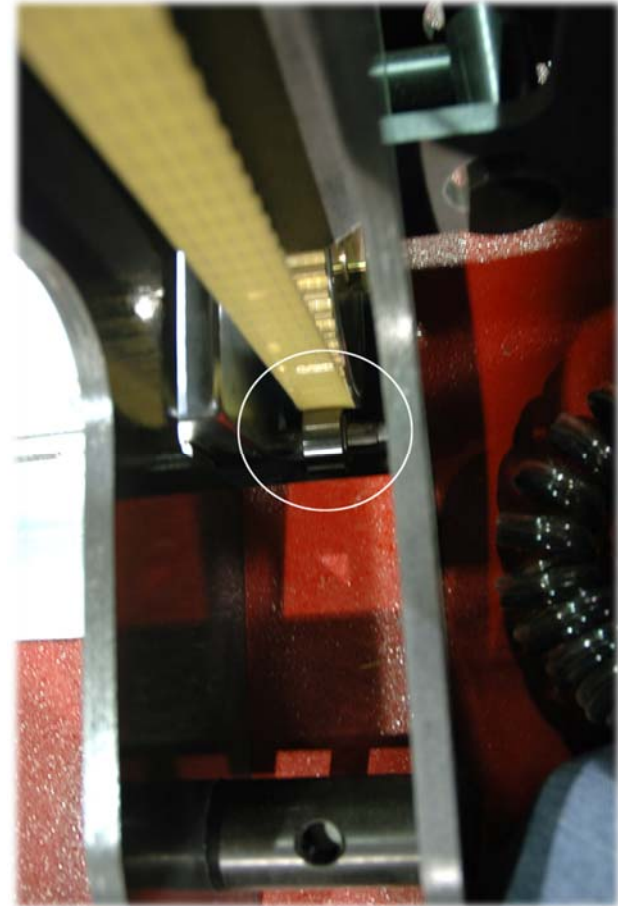

Replace the four cam followers and tighten with an Allen wrench.  
View of motor base pulley with threaded belt  
and re-installed cam followers.

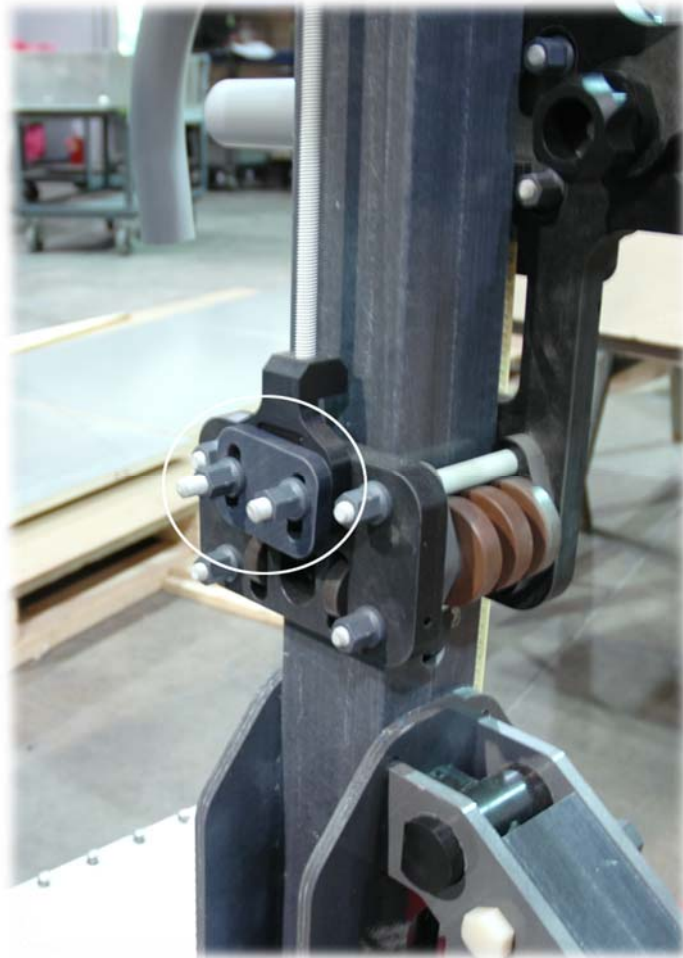

Finish installing the belt by attaching it to the lower belt clamp.  
Remove the two hex nuts.

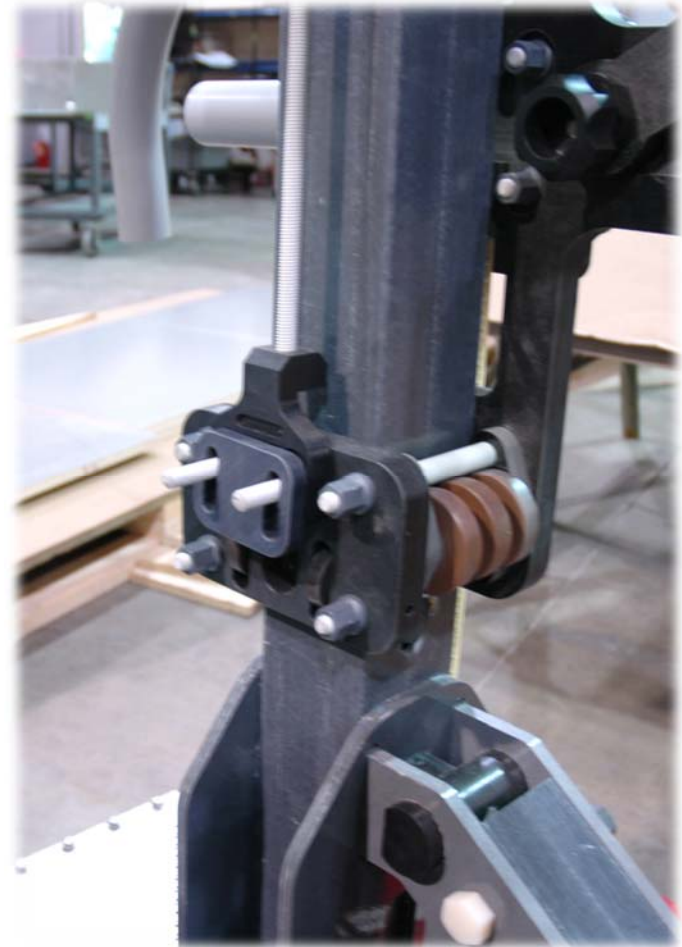

Remove small plate.

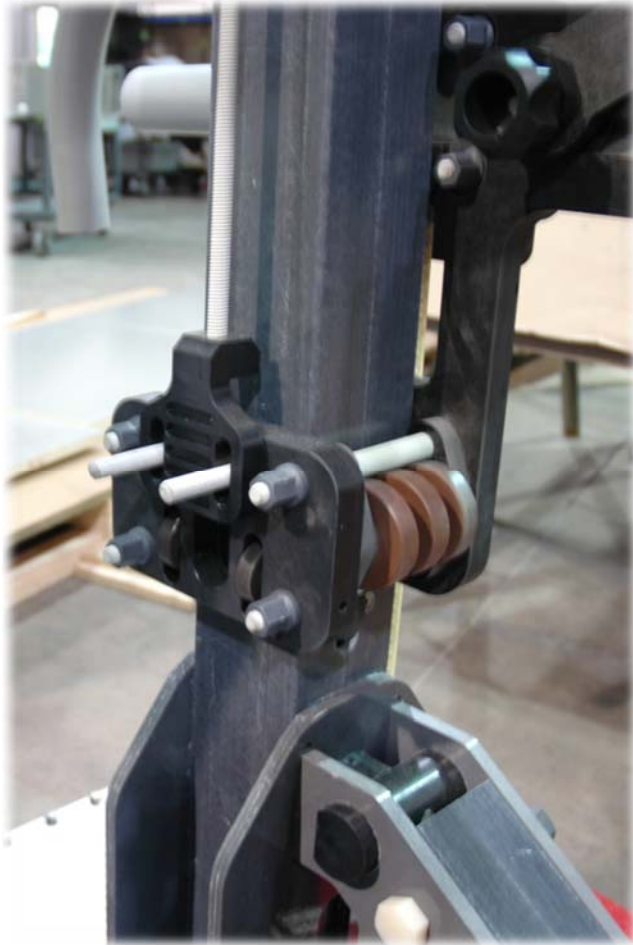

With the teeth facing inward, place the belt between the posts and in the lower belt clamp, and then all the slack out of the belt so that it is as taut as possible.

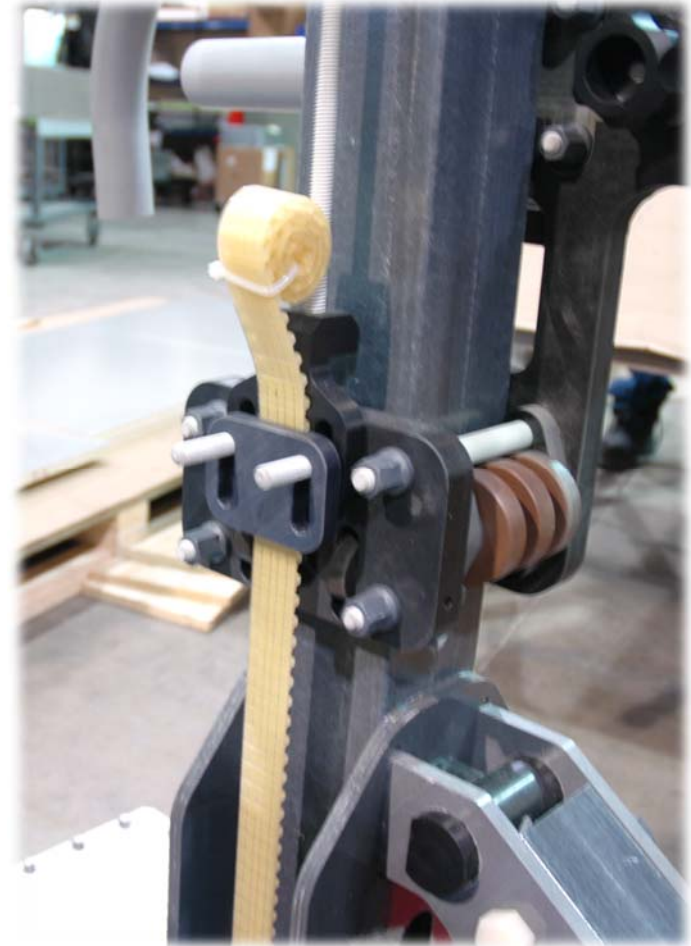

Replace the plate and two hex nuts.

### STEP 9—ADJUST BELT TENSION

- Tighten nut located at top of upper belt clamp.
- Tension the belt until it is snug on the motor gear. Do not over-tension.

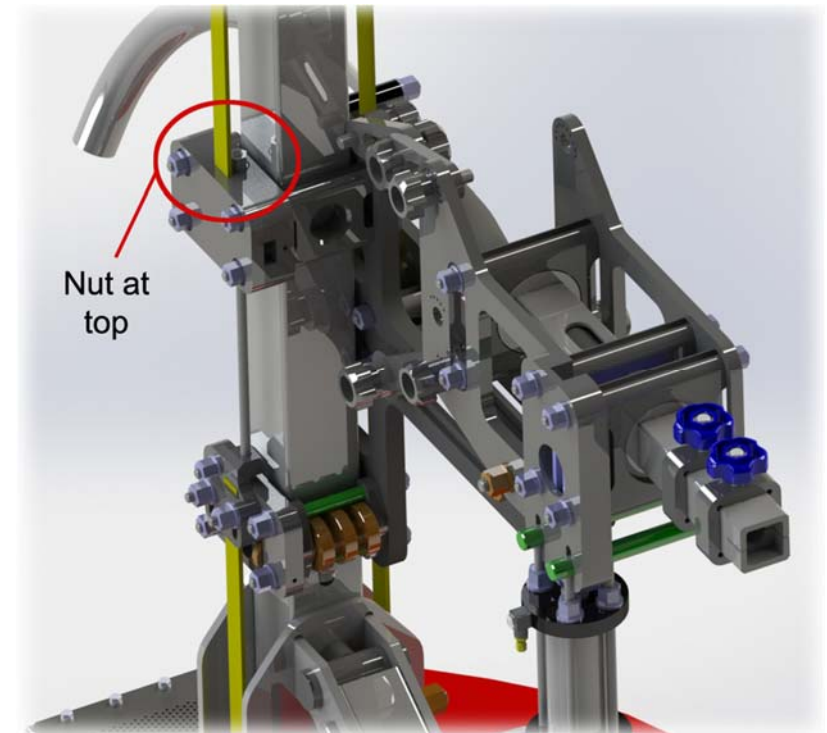

**CAUTION:** To prevent excess belt from getting caught in the carrier during operation, roll up the excess belt and tie it to the carrier.

## **6.0 Additional Installation and Adjustments**

---

### **Install Cable Antenna**

---

1. Feed the antenna cable into the curved elbow fitting, through the middle hose, and out the slotted end of the boom.
2. Attach the end of the cable to the antenna.
3. Insert the stinger into the boom and tighten boom knobs to secure the antenna in place.

## Attach Optional Offset Boom

---



**Note:** The Model 2171B/2170B ships with a stinger-mount boom. If you ordered an optional offset boom (part# 118617), follow these steps to remove the stinger-mount boom and install the offset boom.

1. Rotate the two boom knobs to completely remove them.
2. Remove the stinger-mount and two clamps by sliding them off the boom.

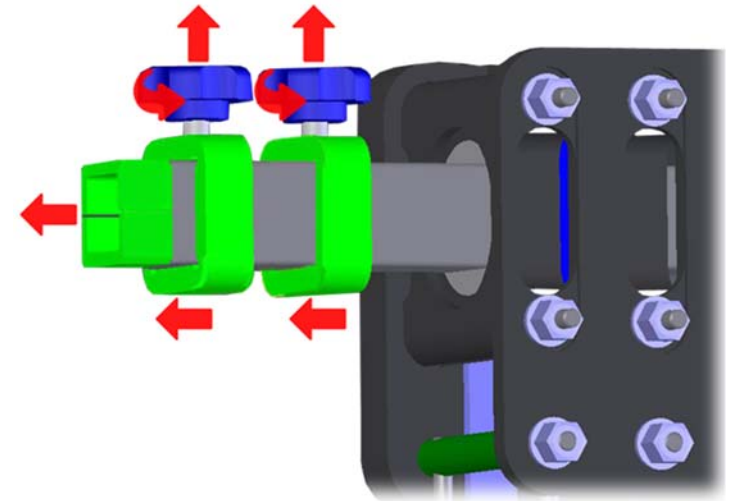

3. Insert the offset boom into the end of the Model 2171B/2170B boom.
4. Tighten the three knobs on the offset boom to secure into place.

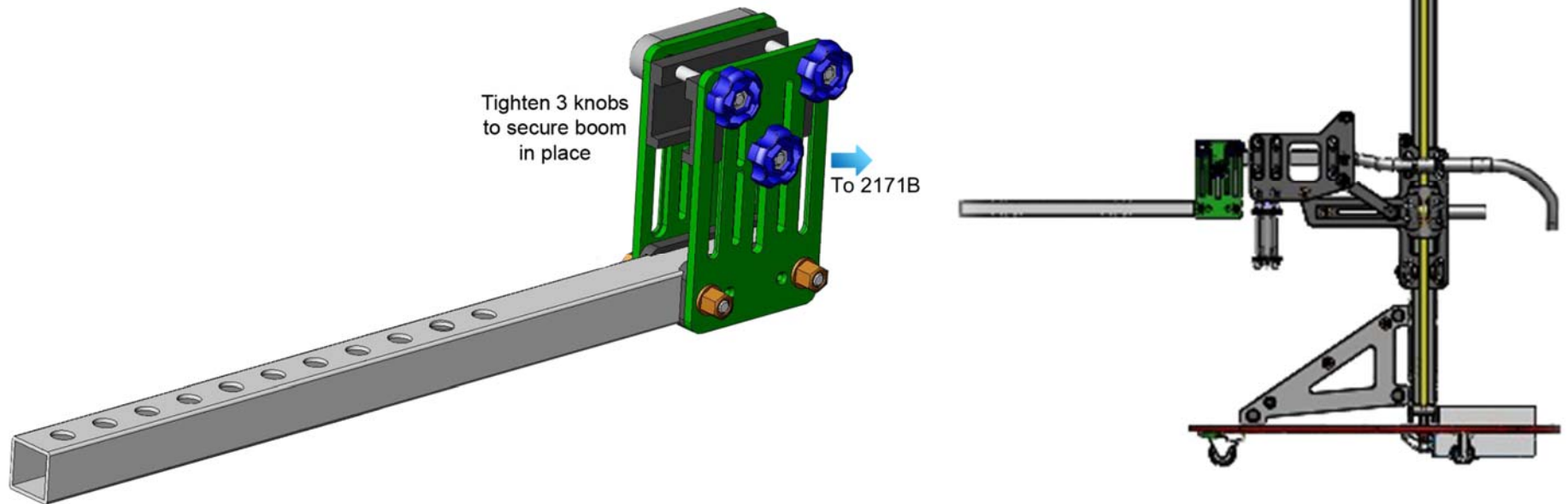

## Install Boresight Links and Level Carrier (2171B Only)



**CAUTION:** Install only one set of boresight links at a time. Never operate the Model 2171B with boresight and non-boresight links installed at the same time.



**Note:** The 3m uses one link; the 5m and the 10m use a set of two links (left and right). For part number information, see *Replacement and Optional Parts* on page 16.



**Note:** Make sure to install the 5m and 10m links in the correct location.

For orientation, face the Model 2171B with the curved elbow fitting extending to the right.

The left link is installed on the left side of the carrier, which is the closer side of the carrier; the right link is installed on the right side, which is the far side.

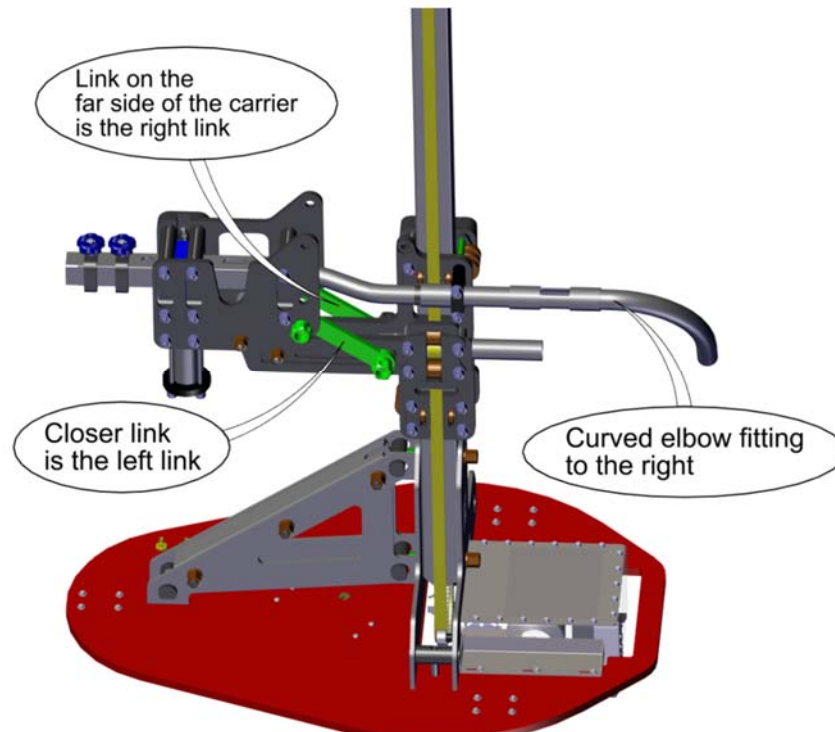



## INSTALL BORESIGHT LINKS

Each boresight link is marked with a pattern of holes that identifies the type of testing it is used to perform.

- 3m link: 3 holes
- 5m links: 5 holes
- 10m links: 10 holes

The carrier is marked with a corresponding pattern of holes indicating the correct installation location for each.

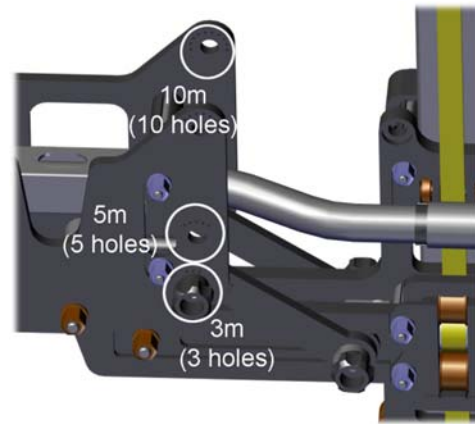

To install a boresight link, match the hole pattern on the link with the hole pattern on the carrier, remove the cam pin, bushings, and knobs, install the link, and then replace pin, bushings, and knobs.

To install a set of links, make sure to install the left link on the left side of the carrier and the right link on the right side; see page 48 for more information.

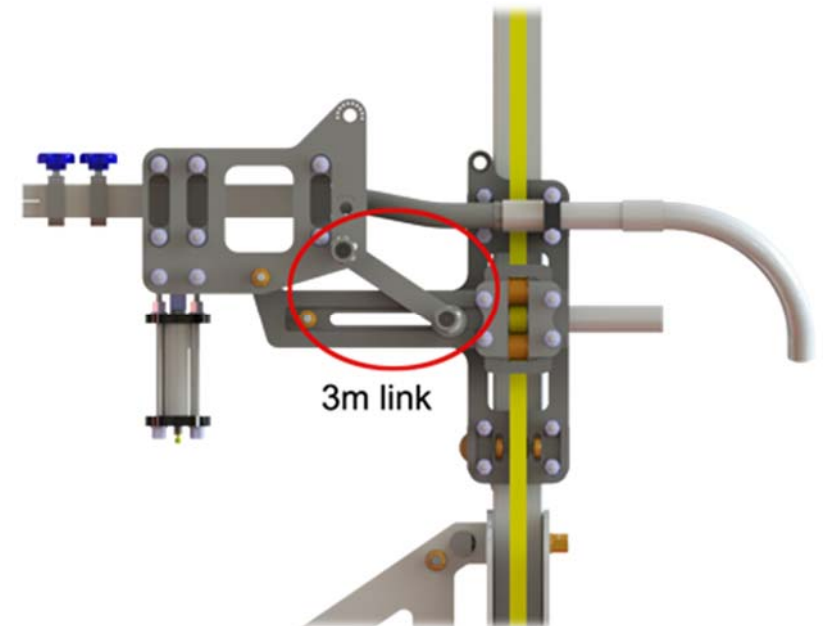

The hole patterns on the carrier match the hole patterns on the links

### LEVEL CARRIER

Place a level gauge on the carrier boom, rotate the cam pin knob until the carrier is level, and then re-tighten the knob. Do not overtighten.

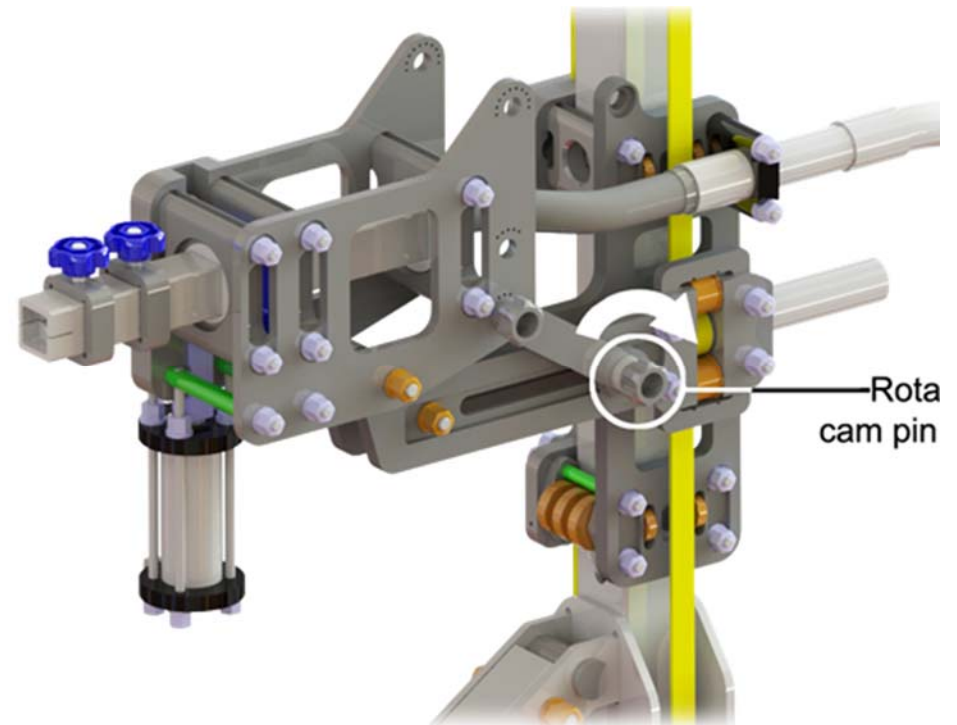

## Install Non-Boresight Links and Level Carrier (2171B Only)



**CAUTION:** Never operate the Model 2171B with boresight and non-boresight links installed at the same time.

### INSTALL NON-BORESIGHT LINKS

If installed, remove boresight links.

Install non-boresight links in the non-boresight locations on the carrier.

To adjust the horizontal level up or down, loosen the inner middle knob and then rotate the outer middle knob. Retighten inner knob to set

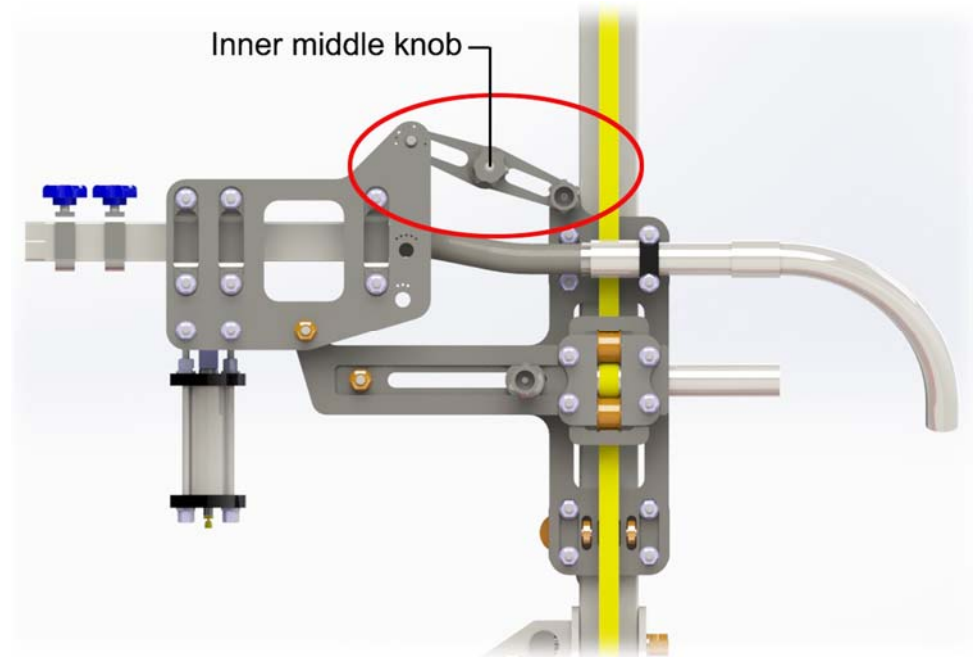

### LEVEL CARRIER

Place a level gauge on the mounting section of the carrier. Tighten all knobs on the non-boresight links. Do not overtighten.

This page intentionally left blank.

## 7.0 Operation

---



**CAUTION:** Before placing into operation, follow the safety information in the ETS-Lindgren *Product Information Bulletin* included with your shipment.



This equipment should be installed, operated, and maintained by qualified personnel.



Stay clear of all moving components on this equipment.

Never stand beneath the carrier, whether moving or stationary.



**Note:** The stationary cam link assembly should never be attached to the carrier when using the boresight.

### Pre-Operational Checklist

---

- Verify that the power lines are connected for the tower, controller, and any other equipment to be used for testing.
- Verify the fiber optic cables are connected.
- Verify the antenna connected to the boom is securely mounted.
- Connect the feed cable to the antenna.
- Before moving the carrier on the mast up or down, verify there are no people standing near the boom.

## Air Polarization Operation

---



**CAUTION:** Prior to using air polarization, make sure that when the antenna polarizes that it turns freely, avoiding contact with anything (the base, the floor, and so on).

The flow limit controls located on the air cylinder are set at the factory. Use the flow limit controls to change the speed.

If polarization is operating at an excessive speed, the antenna mounted to the boom could incur damage.

The automated air polarization assembly includes variable speed polarization cycling using flow limit controls. The air cylinder is made of non-conductive material and will polarize the largest antenna recommended for the tower. The polarization speed range is 3 degrees to 30 degrees per second.

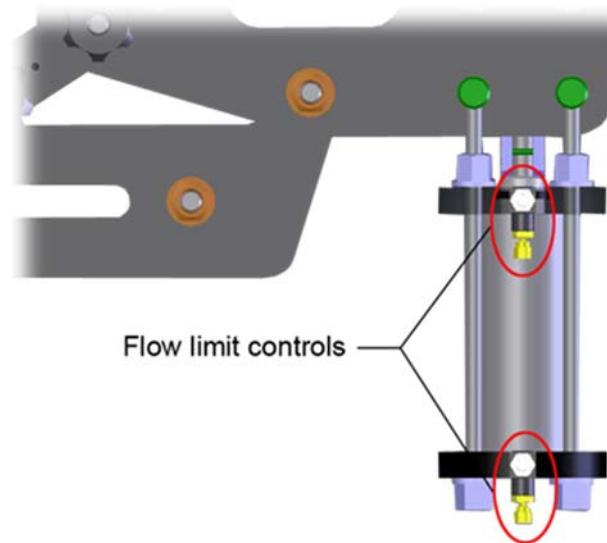

A regulated air supply of 4.0 bar to 5.5 bar (60 psi to 80 psi) is needed for this feature. It is important to have clean and dry air; so we recommend the use of a 40 micron filter in close proximity to the motor base.

Ten meters of UV stabilized air hose is included as well as a 1/8 inch NPT fitting. A metric fitting for a 4 mm tube may be supplied by the customer.

## CONNECTING AIR LINES

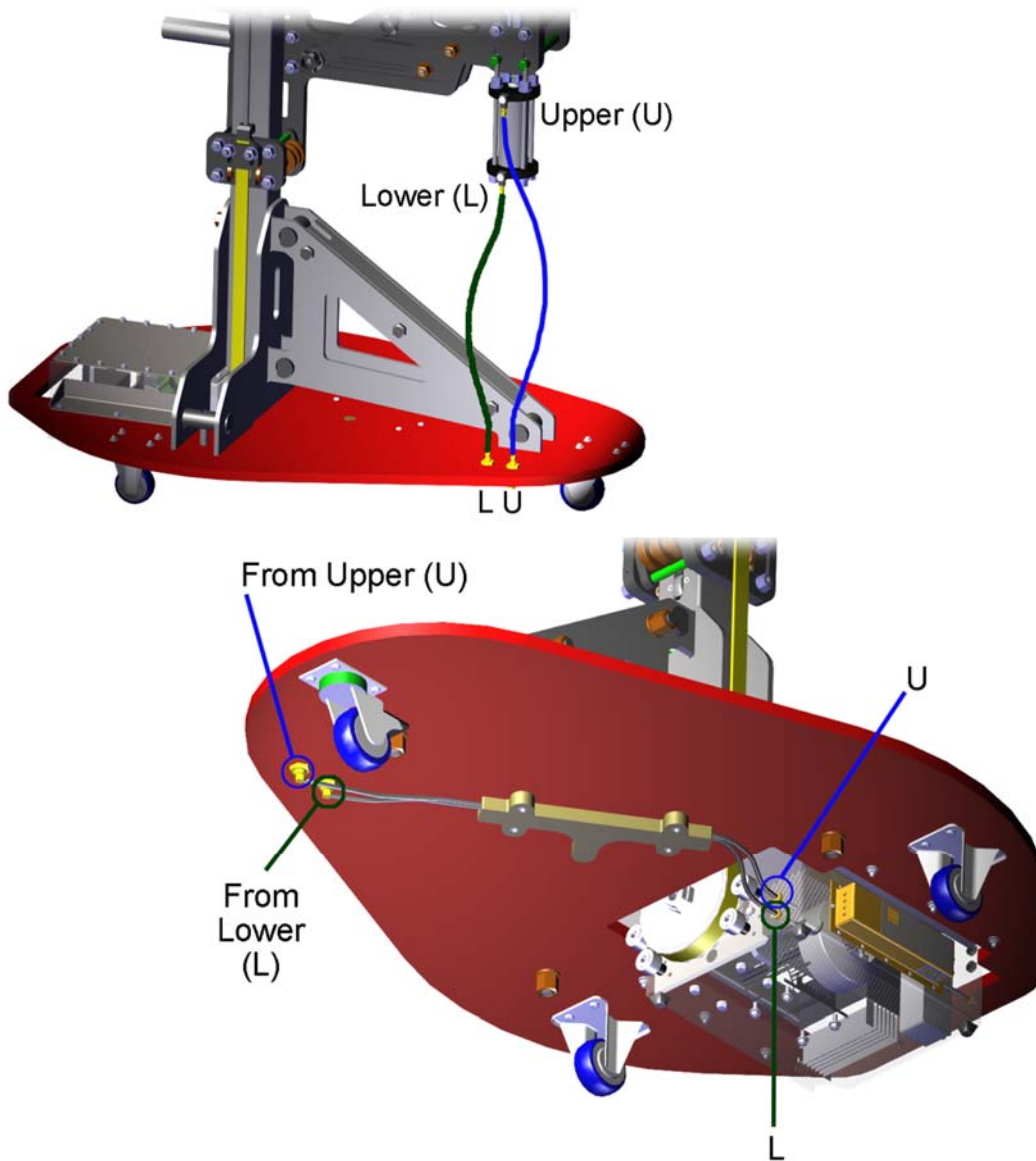

1. **Upper air line**—Attach an air hose from the upper flow limit control on the air cylinder to the right air line connector on the base.

Attach one end of another air hose to the upper air hose connector on the underside of the base. Attach the other end to the upper air hose barb on the motor base.

2. **Lower air line**—Attach an air hose from the lower flow limit control on the air cylinder to the left air line connector on the base.

Attach one end of another air hose to the lower air hose connector on the underside of the base. Attach the other end to the lower air hose barb on the motor base.

## Infrared Remote Controller

---

The Model 2171B/2170B Antenna Positioning Tower is infrared compatible, and can be used with a universal remote control programmed to a specific protocol, such as the ETS-Lindgren Infrared (IR) Remote Controller (included).

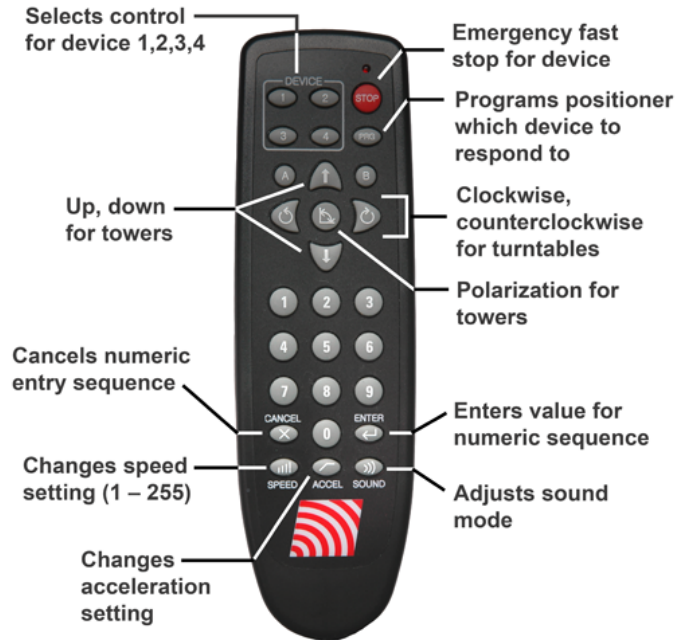

## EMCenter Modular RF Platform

---

The ETS-Lindgren EMCenter™ Modular RF Platform (with EMControl™ Positioner Controller Plug-In Card) may be used to control the Model 2171B/2170B Antenna Positioning Tower. For information on connecting and using the EMCenter, see the *EMCenter Modular RF Platform User Manual*, available for download at [ets-lindgren.com](http://ets-lindgren.com).

The EMCenter replaces the 2090 Controller, which has been discontinued. The basic controller configuration is an EMCenter with an EMControl card. This assembly is ETS part number 125241.

Check [ets-lindgren.com](http://ets-lindgren.com) or contact ETS-Lindgren to ensure that your EMCenter, the EMControl card, the backplane, and display all have the current firmware versions.

**EMCenter:** V5.21 (or later)

**EMControl (7006-001) Card:** V2.5.6 (or later)

**Backplane:** V2.3.0 (or later)

**Display:** V1.4.10 (or later)

The EMCenter is also expandable with a variety of additional options available. Please contact ETS-Lindgren with any questions.





**Note:** If you are unfamiliar with the operation of the EMCenter, see the manual, available for download from ets-lindgren.com.

The EMCenter replaces the 2090 Controller, which has been discontinued.

The 2090 requires firmware revision V 3.21 or higher. It is available for download at ets-lindgren.com and requires the program Flash Upgrade Wizard V 4.0 (also available at ets-lindgren.com).

With the assembly of the tower complete, the controller must be connected to the unit and power applied to both the motor base and controller. See the controller manual for information on connecting the fiber optic cable.

Use the controller to check the clockwise (CW) and counterclockwise (CCW) rotation in both directions by a few degrees. The position in degrees increases (+) in the CW direction and decreases (-) in CCW direction.

## EDIT CONFIGURATION PARAMETERS

Key	Function
PARAM	To edit a configuration parameter: <ul style="list-style-type: none"><li>• Press PARAM key to display the current parameter.</li><li>• Press PARAM key repeatedly to scroll through the parameter list, displaying each parameter.</li></ul>
STEP (INC/DEC)	To scroll up or down the parameter list while viewing a parameter. Reduces the effort necessary to scan through a long parameter list using the PARAM key.
LIMIT/POSITION	Press any of the LIMIT/POSITION selection keys to return the display to that selection.  Press any of the remaining motion keys to return the display to the current position and execute that motion.  Press the PARAM key again to return to the last displayed parameter in the list, allowing easy transition between parameter adjustment and device operation.
INCRM, DECRM, or ENTER	Once the desired limit, position, or parameter is visible in the display window, press INCRM, DECRM, or ENTER to toggle into edit mode.  The lowest adjustable digit will flash on and off.

Key	Function
LOCAL	Press the LOCAL key for that device to switch the flashing digit to the next higher digit. In this way, it is possible to rapidly adjust any digit of a multi-digit parameter or limit.

## TOWER ENCODER CALIBRATION



**Note:** Parameter **C** must be set to **2000** for the Model 2171B/2170B.

Parameter **C**, the encoder calibration parameter, is the setting that converts the encoder count values returned from a motor base into the corresponding centimeter or degree position reading. For towers, this represents the number of encoder counts per meter. This parameter allows a variety of standard, retrofit, and custom devices to be used.

If the given value does not work correctly, the encoder calibration value can be determined using the following procedure:

1. Set the encoder calibration value to 1000.
2. Make sure the tower is positioned to allow at least one meter of travel in the upward direction at an easily measurable height, and then set the current position reading to **000.0**. To allow this, you must adjust the lower limit setting.
3. Use the STEP keys to adjust the height of the carrier until it is one meter above the start point.
4. Record the reading of the display, ignoring the decimal point. For example, **200.0** would be **2000**. This is the encoder calibration value.



**Note:** If the value is below 1000, the resolution of the encoder is low and the EMCenter will not provide 0.1-cm resolution, even though the display shows that digit. If the value is past 9999, the encoder has too many counts per meter and the controller cannot correct for it. In this case, contact ETS-Lindgren for assistance.

5. Enter the encoder calibration value and reset the limits and position information.
6. Test the tower by moving it a known distance and comparing the display to the measured distance traveled. It may be necessary to adjust the encoder calibration value up or down slightly depending on the result.

## **START-UP**

After completing the pre-operational checks, turn on the EMCenter by pressing the power button.

## **SHUTDOWN**

Move the carrier to an accessible height to remove the antenna and confirm the unit has come to a complete stop. Press the power button on the EMCenter to turn it off.

## **Mounting Antennas**

---

The Model 2171B/2170B accepts antennas with the following mount types:

- Stinger-mount boom: Stinger-mount
- Optional offset boom: 7/8–14 thread, 1/4–20 thread

These mount types will maintain the centerline axis during polarization. The antenna should be mounted on the boom as close to the carrier as possible.

Insert the mounting knobs through the holes on the boom and align the mounting holes on the antenna with the threaded end of the mounting knobs. Secure the antenna in place by tightening the threaded knobs into the receptacle mounting holes on the antenna.

## BOOM LOAD LIMITATIONS



**Note:** Boom loading at 25 ft lb (33.9 Nm) measured along the boom from the mast.

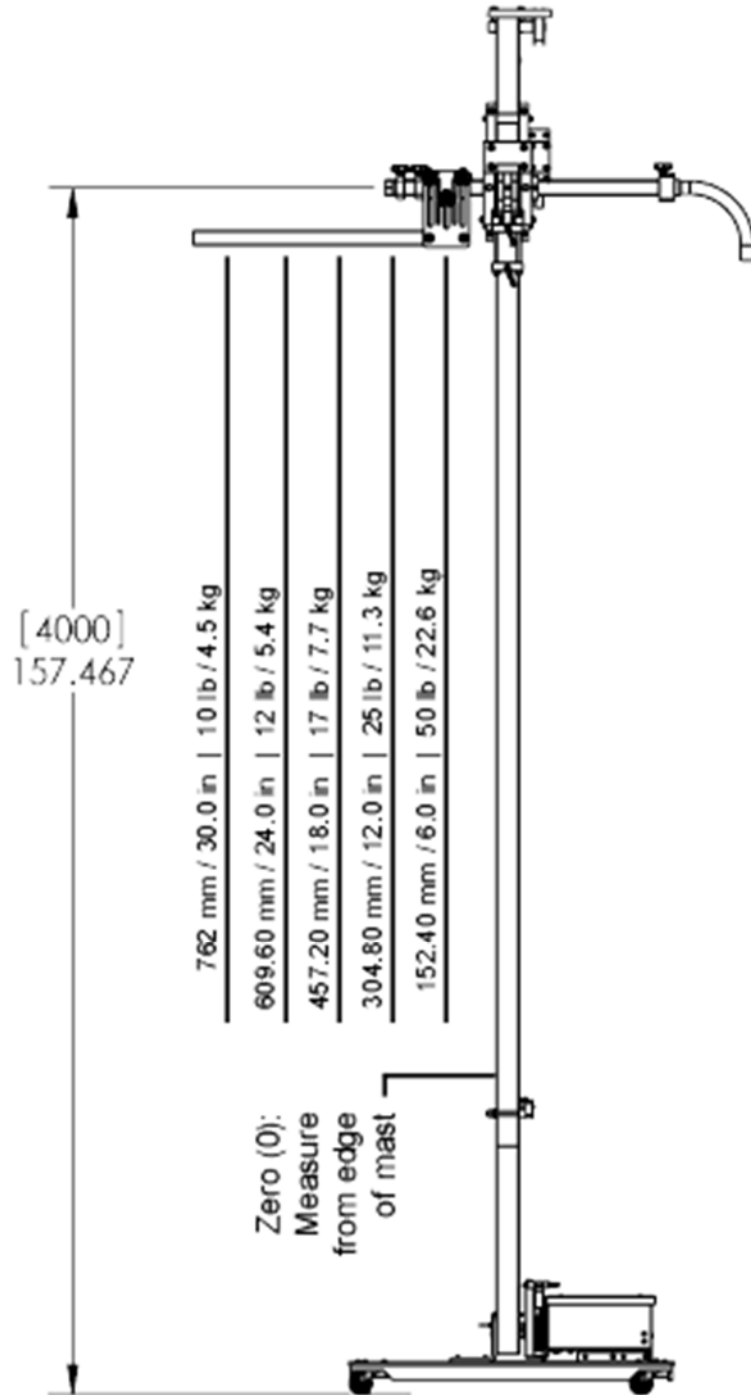

## Appendix A: Warranty

---



**Note:** See the *Product Information Bulletin* included with your shipment for the complete ETS-Lindgren warranty for your Model 2171B/2170B Antenna Positioning Tower.

### **DURATION OF WARRANTIES FOR MODEL 2171B/2170B**

---

All product warranties, except the warranty of title, and all remedies for warranty failures are limited to two years.

<b>Product Warranted</b>	<b>Duration of Warranty Period</b>
Model 2171B/2170B Antenna Positioning Tower	2 Years

This page intentionally left blank.

## Appendix B: EC Declaration of Conformity



### Declaration of Conformity

We, ETS-Lindgren, L.P., 1301 Arrow Point Drive, Cedar Park, TX, 78613, USA, declare under sole responsibility that the:

**Model/Part Number:** 2175 / 2070B / 2071B / 2170B / 2171B

**Model/Part Name:** 2175 / 2070B / 2071B / 2170B / 2171B Antenna Mast with 2175 style motor base

**Date of Declaration:** 01 May, 2005      **Revised Date:** 13 December, 2013

to which this declaration relates, meets the requirements and is in conformity with the relevant EC Directives listed below using the relevant section(s) of the following EC harmonized standards and other normative documents;

**Applicable Directive(s):**

Low Voltage Directive (LVD), 73/23/EEC and its amending directives

Electromagnetic Compatibility Directive (EMC), 2004/108/EC and its amending directives

**Applicable harmonized standard(s) and/or normative document(s):**

EN 55011: Electromagnetic emissions requirements for Industrial, Scientific and Medical (ISM) Equipment

EN 61000-4-11: 1994 Electromagnetic compatibility Part 4, Testing and measurement techniques section 11: Voltage dips, short interruptions and voltage variations immunity tests

EN 61000-4-2: 1995 Electromagnetic compatibility (EMC) – Part 4-2: Testing and measurement techniques - Electrostatic discharge immunity test

EN 61000-4-3: 1997 Electromagnetic compatibility for Electrical and Electronic Equipment, Part 3: Immunity to radiated, radio frequency, electromagnetic fields

EN 61000-4-4: 1995 Electromagnetic compatibility for industrial process measurement and control equipment, Part 4: Electrical fast transient/burst requirements

EN 61000-4-5: 1995 Electromagnetic compatibility for electrical and electronic equipment, Part 5: Surge immunity requirements

EN 61010-1: Safety requirements for electrical equipment for measurement, control, and laboratory use

ENV 50204: 1996 Radiated electromagnetic fields from digital radio telephones - Immunity test

**Authorized Signatories:**

  
ETS-Lindgren, L.P.  
Bryan Sayler, General Manager

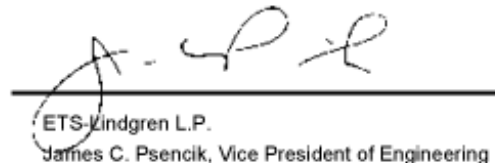
  
ETS-Lindgren L.P.  
James C. Psencik, Vice President of Engineering

The authorizing signatures on this Declaration of Conformity document authorizes ETS-Lindgren, L.P. to affix the CE mark to the indicated product. CE marks placed on these products will be distinct and visible. Other marks or inscriptions liable to be mistaken with the CE mark will not be affixed to these products.

ETS-Lindgren, L.P. has ensured that technical documentation shall remain available on premises for inspection and validation purposes for a period ending at least 10 years after the last product has been manufactured.

This page intentionally left blank.



## **Appendix C: Drawings**

---

The following drawings are located in the pocket of the back cover of the manual:

**118100:** Model 2171B Carrier Assembly (2 Pages)

- **page 1:** Boresight Option shown
- **page 2:** Non-Boresight Option shown

**118200:** Model 2171B Tower Assembly (2 pages)

- **page 1-2:** Boresight Option shown

**118623:** Model 2170B Carrier Assembly

**118624:** Model 2170B Tower Assembly